

Rubidoux Community Services District

Board of Directors

Christopher Barajas
Armando Muniz
Bernard Murphy
F. Forest Trowbridge
Ruth Anderson Wilson



Secretary-Manager

David D. Lopez

Water Resource Management Refuse Collection Street Lights Fire / Emergency Services Weed Abatement

NOTICE AND AGENDA FOR THE RUBIDOUX COMMUNITY SERVICES DISTRICT BOARD MEETING 4:00 PM, March 2, 2017

1. Call to Order - Armando Muniz, President
2. Pledge of Allegiance
3. Roll Call
4. Approval of Minutes for February 16, 2017, Regular Board Meeting
5. Consider to Approve the March 3, 2017, Salaries, Expenses and Transfers
6. Acknowledgements - Members of the public may address the Board at this time on any non-agenda matter.
7. Correspondence and Related Information
8. Manager's Report:

ACTION ITEMS:

9. Inspect New Type I Engine in Service at Rubidoux CSD Fire Station: **DM 2017-08**
10. Consideration to Award the Purchase of two (2) Utility Vehicles for Water Operations: **DM 2017-09**
11. Consideration to Authorize the Application for District Credit Card for RCSD Purposes: **DM 2017-10**
12. Directors Comments - Non-action
13. Adjournment

Closed Session: At any time during the regular session, the Board may adjourn to a closed executive session to consider matter of litigation, personnel, negotiations, or to deliberate on decisions as allowed and pursuant with the open meetings laws. Discussion of litigation is within the Attorney/Client privilege and may be held in closed session.

Authority: Government code 11126-(a) (d) (q).

4. APPROVAL OF MINUTES FOR FEBRUARY 16, 2017, REGULAR
MEETING MINUTES

MINUTES OF REGULAR MEETING
February 16, 2017
RUBIDOUX COMMUNITY SERVICES DISTRICT

DIRECTORS PRESENT: Ruth Anderson Wilson
Armando Muniz
Bernard Murphy
F. Forest Trowbridge
Christopher Barajas

DIRECTORS ABSENT:

STAFF PRESENT: David Lopez, General Manager
Steve Appel, Asst. General Manager
Krysta Krall, Manager Fiscal Services
Brian Jennings, Accounting/Budgeting Manager

Call to order: the meeting of the Board of Directors of the Rubidoux Community Services District by Director Muniz, at 4:00 P.M., Thursday, February 16, 2017, at the District Office, 3590 Rubidoux Boulevard, Jurupa Valley, California.

ITEM 4. APPROVAL OF MINUTES

Approval of the Regular Minutes for February 2, 2017, was unanimously approved.

The motion was carried unanimously.

Ayes – 5 (Wilson, Muniz, Murphy, Trowbridge, Barajas)

Noes - 0

ITEM 5. Consider to Approve the February 17, 2017, Salaries, Expenses and Transfers.

Approve February 17, 2017 Salaries, Expenses and Transfers.

Director Wilson moved and Director Trowbridge seconded to approve the February 17, 2017, Salaries, Expenses and Transfers.

The motion was carried unanimously.

Ayes – 5 (Wilson, Trowbridge, Muniz, Murphy, Barajas)

Noes - 0

ITEM 6. PUBLIC ACKNOWLEDGE OF NON-AGENDA MATTERS

There were no members of the public to address the Board.

ITEM 7. CORRESPONDENCE AND RELATED INFORMATION

The first article was about the Oroville Dam and the spillways that have been compromised. It's the first time since the dam has been completed that the spillway was ever used; nearly fifty years. All that water is just going to the river system down in the delta. The next article – conservation is still high, state water on state water officials. There's a push at the state level to have conservation as a way of life in California, regardless of the availability of water or lack of water they want to change habits and perception and conserve water. The next one is Drought dwindling in Southern California. Eastern MWD just relaxed their conservation from a stage 3 to a stage 1. Stage 1 encourages wasteful use of water.

ITEM 8. MANAGER'S REPORT

Operations Report:

Jurupa is still taking about 1,700 gpm of water. That equates to about 2.5 ± million gallons per day.

Emergency and Fire Report:

The Incident Report for January 1 –January 31, 2017 there were a total of 282 calls, in comparison to the same period in 2016, there were a total of 281 calls. The year to date total is 282, compared to 281 in 2016.

ITEM 9. DM 2017-06. Receive and File Cash Asset Report Ending February 2017 for All District Fund Accounts.

The year-to-date Interest ending January 31, 2017, is \$81,142.00 for District controlled accounts. With respect to District "Funds in Trust", we show \$3,349.00 which has been earned and posted. The District has a combined YTD total of \$84,497.00 as of January 31, 2017.

With respect to the District's Operating Funds (Excluding Operating Reserves), we show a balance of \$4,858,556.00 ending January 31, 2017. That is **\$16,558.00 MORE** than July 1, 2016, beginning balance of \$4,841,998.00.

The District's Field/admin Fund continues to grow and current fund balance nears \$285,947.00.

Submitted for the board of directors consideration is the *January 2017, Statement of Cash Asset Schedule Report* for your review and acceptance this evening.

Director Trowbridge moved and Director Wilson seconded to Receive and File the Statement of Cash for the Month of January 2017 for the Rubidoux Community Services District.

The motion was carried unanimously.

Ayes – 5 (Wilson, Trowbridge, Muniz, Murphy, Barajas)

Noes - 0

ITEM 10. DM 2017-07. Present District's Water Replacement Program and Associated Projects to the Board.

The Rubidoux Community Services District has assessed and collected Water Replacement charges as part of monthly fixed and variable unit charges. In the early 1990's, the Water Replacement Fund was the brain-child of past RCSD Director Jim Gould and embraced by the full Board. When collected these monies are earmarked and segregated for needed repair and replacement of existing water infrastructure and appurtenances. Depending upon the season, typical assessment range from \$10,000.00± to \$15,000.00± per month. Incidentally, the Water Replacement Fund has a Fund Balance of \$527,081.30 as of January 31, 2017.

Tonight's presentation by Staff will revisit past Water Replacement Projects.

Mr. Steve Appel, District Engineer, presented a detailed presentation on the Water Replacement Program and Associated Projects to the Board.

No recommendation necessary. Presentation/Status report only.

ITEM 11. Directors Comments – Non action.

Director Muniz adjourned the February 16, 2017, Regular Board meeting.

5. CONSIDER TO APPROVE THE MARCH 3, 2017, SALARIES,
EXPENSES AND TRANSFERS

RUBIDOUX COMMUNITY SERVICES DISTRICT
MARCH 2, 2017 (BOARD MEETING)
FUND TRANSFER AUTHORIZATION

NET PAYROLL 3/10/2017	56,800.00
WIRE TRANSFER: FEDERAL PAYROLL TAXES 3/13/17	27,100.00
WIRE TRANSFER: STATE PAYROLL TAXES 3/13/17	5,100.00
WIRE TRANSFER: VACATION BUYBACK	10,200.00
WIRE TRANSFER: VACATION BUYBACK FED/STATE PR TAX 3/13/17	1,000.00
WIRE TRANSFER: TO CREDIT UNION	2,300.00
WIRE TRANSFER: PERS RETIREMENT	16,042.00
WIRE TRANSFER: PERS HEALTH PREMIUMS	-
WIRE TRANSFER: SECTION 125	424.61
WIRE TRANSFER: SECTION 457	2,765.00

3/3/2017 WATER FUND TO GENERAL FUND-Payables	36,813.04
WATER FUND TO GENERAL FUND-Trash	107,241.71
WATER FUND TO SEWER FUND	102,110.92
SEWER FUND TO GENERAL FUND-Payables	172,280.41

3/3/2017 SEWER FUND CHECKING TO LAIF SEWER OP	-
LAIF SEWER OP TO SEWER FUND CHECKING	70,000.00
GENERAL FUND CHECKING TO LAIF PROP TAX	-
GENERAL FUND CHECKING TO LAIF SEWER ML	-
GENERAL FUND PROPERTY TAX TO LAIF PT	-
GENERAL FUND PROPERTY TAX TO GF CHECKING	25,000.00
GENERAL FUND CHECKING TO GENERAL FUND PROP TAX	-
LAIF GENERAL TO GENERAL FUND CHECKING	-
LAIF PROPERTY TAX TO GF CHECKING	580,000.00
COP PAYBACK TO LAIF-COP PAYBACK	40,233.95
WATER REPLACEMENT TO LAIF-W.R.	5,530.51
LAIF WATER ML TO LAIF WATER OP	-
LAIF WATER OP TO WATER FUND CHECKING	-
LAIF WATER RESERVE TO LAIF WATER OP	-
LAIF WATER REPLACE TO LAIF WATER OP	-
LAIF WATER OP TO LAIF WATER RESERVE	-
WATER FUND CHECKING TO LAIF WATER RESERVE	-
WATER FUND CHECKING TO LAIF WATER OP	145,000.00
LAIF COP TO GENERAL FUND CHECKING	-

NOTES PAYABLE

<u>DESCRIPTION</u>	<u>BALANCE</u>		<u>PAYMENT</u>	<u>DUE DATE</u>
City of Riverside (Headworks Replacement)	27,128	Prin.	13,564	Oct-17
U.S. Bank Trust (1998 COP's Refunding)	4,655,000	Prin.	-	Jun-17
U.S. Bank Trust (1998 COP's Refunding)	1,272,114	Intr.	118,581	Jun-17
MN Plant-State Revolving Loan	4,990,243	Prin.	117,956	Jul-17
MN Plant-State Revolving Loan	1,201,087	Intr.	64,142	Jul-17

01 General Fund

Control	Vendor	Obligat'n Description	Transaction Account	Amount
	1860	ASSOCIATION OF GOVT. ACCOUNTANTS 67425 Dues K. Krall	A01-5680-000	110.00
	1875	AT&T 67384 Phone Chrgs	A01-5670-000	123.22
	3735	CHARTER BUSINESS 67394 Internet 3/6-4/5	A01-5650-000	125.00
	3848	COMM-TECH COMMUNICATIONS CO. 67460 On-hold Music Source	A01-5650-000	361.75
	3855	COMPUTER WORKS 67395 Fundware Support	A01-5885-000	312.50
	4900	DURNEY, DON 67435 Feb'17 Grdng Srv	A01-5645-000	135.00
	8078	HARRIS COMPUTER SYSTEMS 67461 C/O 1v1 - On-site Training	A01-1835-000	6,400.00
	12715	LUCE COMMUNICATIONS: dba ABG COMM. 67409 Mar'17 Postage	A01-5664-000	3,000.00
		67441 WA41 FN 02/17	A01-5650-000	212.70
		67442 WA41 INV 2/17	A01-5650-000	763.00
	12715	LUCE COMMUNICATIONS: dba ABG COMM.		3,975.70 **
	13200	MERIT OIL COMPANY 67411 Gasoline	A01-5700-000	155.35
		67443 Gasoline	A01-5700-000	101.17
	13200	MERIT OIL COMPANY		256.52 **
	14201	NELCO 67444 Check Stock	A01-5675-000	161.30
	16893	PRUDENTIAL OVERALL SUPPLY CO 67445 Floor Mats	A01-5645-000	53.30
	18356	RELIABLE WORKPLACE SOLUTIONS 67413 Supplies	A01-5675-000	132.58
		67448 Credit	A01-5675-000	-19.30
		67449 Supplies	A01-5675-000	81.08
	18356	RELIABLE WORKPLACE SOLUTIONS		194.36 **
	18436	RIVERSIDE COUNTY CDF 67416 Q2 FY 16/17	A01-5823-020	482,060.42
	19775	STANDARD INSURANCE 67456 March'17 Life/Ltd/ Ins	A01-5030-000	901.09

OK
2/23/2017

01 General Fund

Control	Vendor	Obligat'n Description	Transaction Account	Amount
	20845	TRI-CO DISPOSAL, INC		
		67462 Commercial Trash 2/9-2/22	A01-5410-010	47,160.45
		67463 Residential Trash 2/9-2/22	A01-5410-010	60,081.26
		67464 RCSD Share Commercial	A01-5410-010	-4,717.08
		67465 RCSD Share Residential	A01-5410-010	-640.53
		67466 Billing Fee	A01-5410-010	-3,000.00
	20845	TRI-CO DISPOSAL, INC		98,884.10 **
	22090	VSP-VISION SERVICE PLAN		
		67467 March '17 Vision Ins.	A01-5030-000	315.82
01 General Fund				594,370.08 **

30 Water Fund

Control	Vendor Obligat'n Description	Transaction Account	Amount
1810	AQUA METRIC SALES CO 67424 3/4" Meters	A30-1515-000	10,005.13
1875	AT&T 67384 Phone Chrgs	A30-5650-000	20.24
	67384 Phone Chrgs	A30-5670-000	281.12
			301.36 **
1875	AT&T		301.36 **
2004	B.P.S. B's POOL SUPPLIES 67426 Sodium Hypo	A30-5652-000	351.48
2030	BABCOCK, E S & SONS, INC 67385 Water Analyses	A30-5340-000	490.00
	67386 Water Analyses	A30-5340-000	75.00
	67387 Water Analyses	A30-5340-000	67.50
	67388 Water Analyses	A30-5340-000	112.50
	67389 Water Analyses	A30-5650-005	50.00
	67390 Water Analyses	A30-5340-000	275.00
	67392 Water Analyses	A30-5340-000	45.00
	67393 Water Analyses	A30-5650-005	165.00
	67427 Water Analyses	A30-5340-000	45.00
	67428 Water Analyses	A30-5650-005	30.00
	67429 Water Analyses	A30-5650-005	80.00
	67430 Water Analyses	A30-5650-005	110.00
	67431 Water Analyses	A30-5650-005	170.00
	67458 Water Analyses	A30-5340-000	120.00
2030	BABCOCK, E S & SONS, INC		1,835.00 **
2150	BAVCO 67432 Regulator	A30-5650-000	108.34
3735	CHARTER BUSINESS 67394 Internet 3/6-4/5	A30-5650-000	125.00
3921	CROWN ACE HARDWARE 67396 Fasteners	A30-5642-000	7.93
	67397 Cement F.H. Crestmore 34th	A30-5640-000	75.32
	67433 R & M Equip	A30-5630-000	6.45
	67434 R & M Water	A30-5640-000	32.22
3921	CROWN ACE HARDWARE		121.92 **
9505	CARQUEST AUTO PARTS 67398 R&M Field Office	A30-5642-000	7.21
	67437 Oil	A30-5630-000	32.30
9505	CARQUEST AUTO PARTS		39.51 **
9510	SO CAL TRUCKWORKS 67399 R & M Truck	A30-5620-000	142.50

30 Water Fund

Control	Vendor	Obligat'n Description	Transaction Account	Amount
			** Continued **	
9510	SO CAL TRUCKWORKS			
		67400 R & M Truck	A30-5620-000	57.21
9510	SO CAL TRUCKWORKS			199.71 **
9533	INDUSTRIAL METAL SUPPLY CO.			
		67438 Fasteners	A30-5642-000	55.32
9657	INLAND COUNTIES WATER ASSOC			
		67401 Seminar-Bugbee/Martinez	A30-5690-000	50.00
9682	INLAND WATER WORKS SUPPLY CO			
		67402 Stock	A30-5650-000	387.91
		67403 Sleeve	A30-5640-000	615.60
9682	INLAND WATER WORKS SUPPLY CO			1,003.51 **
9718	BERNELL HYDRAULICS, INC.			
		67404 Supplies	A30-5640-000	149.30
		67405 Pump Rpr	A30-5640-000	242.41
9718	BERNELL HYDRAULICS, INC.			391.71 **
11452	KH METALS & SUPPLY			
		67406 Fasteners	A30-5642-000	20.17
		67407 Union	A30-5640-000	12.73
		67439 6" Pipe	A30-5650-000	107.39
		67440 Valve	A30-5650-000	19.44
11452	KH METALS & SUPPLY			159.73 **
12610	NORTHROP GRUMMAN COM INFO SVCS, INC			
		67408 Handheld Connector	A30-5650-000	121.40
13152	McMASTER-CARR SUPPLY CO			
		67410 Signage	A30-5642-000	209.32
		67447 Sample Bags	A30-5640-000	31.09
13152	McMASTER-CARR SUPPLY CO			240.41 **
13200	MERIT OIL COMPANY			
		67411 Gasoline	A30-5700-000	1,009.75
		67443 Gasoline	A30-5700-000	657.63
13200	MERIT OIL COMPANY			1,667.38 **
16893	PRUDENTIAL OVERALL SUPPLY CO			
		67445 Floor Mats	A30-5642-000	55.38
18003	R&D MECHANICAL SUPPLY, INC			
		67412 Bug Screens	A30-5640-000	608.79
		67446 Fire Hydrnt	A30-1515-000	1,676.59
18003	R&D MECHANICAL SUPPLY, INC			2,285.38 **
18723	RUBIDOUX TIRE			

30 Water Fund

Control	Vendor Obligat'n Description	Transaction Account	Amount
	18723 RUBIDOUX TIRE	** Continued **	
	67417 R&M Truck	A30-5620-000	270.14
	67418 R&M Truck	A30-5620-000	811.35
	18723 RUBIDOUX TIRE		1,081.49 **
	19130 SCE		
	67452 Water Pump Energy	A30-5235-000	198.47
	67455 Wtr Pump Energy	A30-5235-000	13,205.57
	19130 SCE		13,404.04 **
	19775 STANDARD INSURANCE		
	67456 March'17 Life/Ltd/ Ins	A30-5030-000	1,564.12
	22090 VSP-VISION SERVICE PLAN		
	67467 March '17 Vision Ins.	A30-5030-000	695.72
	23385 WELLS' TAPPING SERVICE		
	67419 Hot Tap	A30-5640-000	400.00
	23568 WESTERN MUNICIPAL WATER DISTR		
	67420 Dec'16 Brine	A30-5650-005	150.00
	67421 Permits	A30-5685-000	400.00
	23568 WESTERN MUNICIPAL WATER DISTR		550.00 **
30 Water Fund			36,813.04 **

40 Sewer Fund

Control	Vendor Obligat'n Description	Transaction Account	Amount
1875	AT&T		
	67384 Phone Chrgs	A40-5670-000	41.05
2030	BABCOCK, E S & SONS, INC		
	67391 Lab Fees	A40-5340-000	240.00
	67459 Lab Fees	A40-5340-000	240.00
2030	BABCOCK, E S & SONS, INC		480.00 **
8012	HACH COMPANY		
	67436 R & M Sewer	A40-5640-000	49.75
13200	MERIT OIL COMPANY		
	67411 Gasoline	A40-5700-000	77.67
	67443 Gasoline	A40-5700-000	50.59
13200	MERIT OIL COMPANY		128.26 **
18386	RICHARDS, WATSON, GERSHON ATTNYS		
	67450 City Riv Litgn	A40-5825-000	17,699.08
18409	RIVERSIDE CITY		
	67414 Dec'16 Treatment	A40-5320-000	101,540.91
	67415 Dec'16 Surcharge	A40-5320-000	30,449.02
18409	RIVERSIDE CITY		131,989.93 **
19130	SCE		
	67451 Swr Pump Energy	A40-5235-000	662.34
	67453 Swr Pump Energy	A40-5235-000	2,120.64
	67454 Swr Pump Energy	A40-5235-000	274.33
19130	SCE		3,057.31 **
23350	WEBB, ALBERT A. ASSOCIATES INC.		
	67457 City Riv Litgn	A40-5825-000	395.00
23993	GRAINGER		
	67422 Supplies	A40-5640-000	26.77
24500	XYLEM WATER SOLUTIONS USA, INC.		
	67423 Rpr Pump- Reg Lift	A40-5640-000	18,413.26
40 Sewer Fund			172,280.41 **

6. ACKNOWLEDGEMENTS – MEMBERS OF THE PUBLIC MAY ADDRESS
THE BOARD AT THIS TIME ON ANY NON-AGENDA MATTER

7. CORRESPONDENCE AND RELATED INFORMATION

Subscribe Today | Customer Service | P-Edition | Advertise | Search Website | Top Workplaces | UnidosSC.com | Weather

News | Sports | Entertainment | Business | Life | Opinion | Blogs | Cannifornian | Obits | Press-Enterprise Rewards

DISCOPY/BOARD PAPER
 CARS
 JOBS
 HOMES
 DEALS
 CLASSIFIEDS

City News | Politics | Topics | Environment | Education | Announcements | Traffic | Photos | Blogs



NEWS
Here's why 'The Voice' judges can't stop talking about Temecula



NEWS
Stranded hikers escorted down from Mount San Jacinto



SPORTS
High school scoreboard: Monday, February 27



NEWS
'House Hunters' episode film in Hemet set to air

NEWS

The reason Rancho California Water District is pondering a rate hike

Despite storms, district expects needing to buy expensive imported water this summer due to the recent drawdown of Vail Lake.

[G+](#) [Like](#) [Share](#) [Tweet](#) [Email](#) [Share](#)

By AARON CLAVERIE / STAFF WRITER

Published: Feb. 18, 2017 Updated: Feb. 20, 2017 4:15 p.m.



FRANK BELLINO, FILE PHOTO

Lake Oroville is overflowing. The pool in the backyard hasn't needed a splash of water for months. And the neighbor's formerly barren yard has a lush canopy of verdant weeds.

So why is the Rancho California Water District – which serves Temecula, Wine Country and some surrounding areas – warning customers about possible rate hikes later this year and urging conservation?

"This is the problem," Jeff Armstrong, the district's general manager, said Thursday. "Everyone's saying the drought's over. And you see what's happening in Northern California, the visuals."

The main issue, he said, is that this region, which has its own microclimate, is still recovering from a long period of below-average rainfall. In some years, he said, the region was getting less than half the rain it normally gets during a weather year.

During that time, the district used water from Vail Lake to augment the local supply, which, he said, helped keep rates lower than neighboring districts.

THE BIG DRAWDOWN

Rancho Water is asking ratepayers to continue conserving water due to the recent drawdown of Vail Lake, which will force the district to purchase more expensive imported water to service homes, businesses and farms in the coming fiscal year

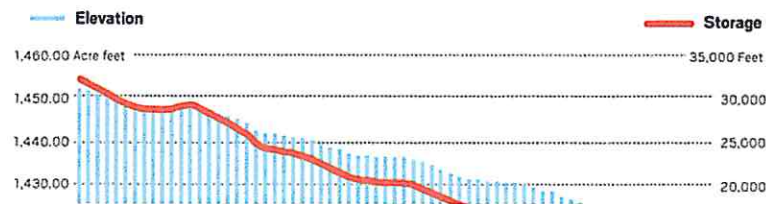

BMW of Riverside

888-847-4027

Riverside Yellow Pages

THINGS TO DO

Most Popular Events See All

hum

P.O.D.

Mar 4
Morongo

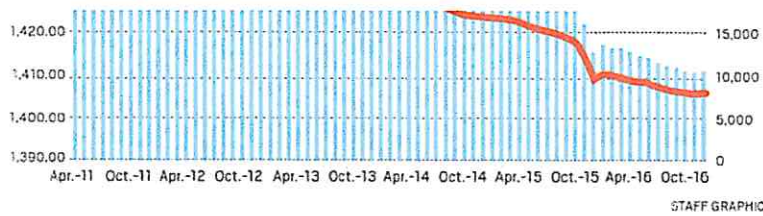

Assistant Director of Nurses

Riverside Healthcare Center

Riverside Behavioral Healthcare Center is an American Healthcare Association National Award Winning Mental Health facility. We are seeking a new Assistant Director of Nurses to join our amazing team. Riverside Behavioral Healthcare Center is a 120 bed locked mental health care facility providing effective care to adults 18-64



But the district – which imports around 60 percent to 75 percent of the 76,000 acre-feet it supplies each year – has drawn as much water as it can from the lake due to water quality issues: The lake needs enough water to allow sediment to sink to the bottom.

The recent storms, including this weekend’s deluge, have helped a lot – thousands of acre-feet have been added relatively quickly – but the lake is still about one-quarter of capacity and there is no plan any time soon to resume boat launches, which were suspended indefinitely due to the low water level.

RELATED: [Vail Lake museum created from lost rods, lures ... even boats](#)

In the past, the district wasn’t allowed to draw down the lake so severely because of a longstanding agreement that required a minimum elevation for recreation purposes.

That agreement was effectively voided when the district spent \$55 million to purchase the land surrounding the lake in a 2014 bankruptcy proceeding.

Armstrong said the investment helped the district bank about \$7.5 million in savings by using Vail Lake water instead of buying imported water.

Looking ahead, Armstrong said the district will be able to buy all the water it wants from the state water project, due to the tremendous rain and snowpack levels in the northern reaches of the state, but that water is considerably more expensive than local supply.

“We’re going to need a lot,” he said, noting the difference in cost runs about \$150 per acre-foot for local water versus \$1,000 an acre-foot for imported water.

An acre-foot of water equals 326,000 gallons, about the amount two families use in a typical year.

1 2 Next Page

Sign up to get breaking news updates delivered to your inbox.

Sign up

DIGITAL & DRIVEWAY DELIVERY - 50% OFF

MORE FROM TEMECULA

Subscribe Today | Customer Service | P-Edition | Advertise | Search Website | Top Workplaces | UnidosSC.com | Weather
News | Sports | Entertainment | Business | Life | Opinion | Blogs | Cannifornian | Obits | Press-Enterprise Rewards

CARS
JOBS
HOMES
DEALS
CLASSIFIEDS

Editorials | Editorial Cartoons | Local Views | Election Editorials | Letters to the Editor | Submit a Letter



ENTERTAINMENT
Ritual Brewing Co. in Redlands marks 'Fat Hog Tuesday'



NEWS
Stranded hikers escorted down from Mount San Jacinto



SPORTS
High school scoreboard: Monday, February 27



NEWS
'House Hunters' episode film in Hemet set to air

OPINION

More water, but still more controls

G+1 Like Share Tweet Email Share

PRESS-ENTERPRISE EDITORIAL BOARD
Published: Feb. 14, 2017 Updated: 3:50 p.m.

California's water regulators just can't give up their control of our lawn watering and shower times, despite a federal analysis showing that most of the state is no longer in drought.

Even as Gov. Jerry Brown declared a state of emergency for 50 counties last month due to flooding, erosion and mud flows, and the snowpack in the Sierra Nevada is nearly twice average levels, the State Water Resources Control Board voted unanimously last week to extend water conservation rules until at least May.

In April 2015, Gov. Brown took the unprecedented step of imposing statewide water restrictions, ordering urban water agencies to reduce usage 25 percent below 2013 levels. Those rules were eased in May 2016, when the State Water Board lifted them for the 80 percent of water agencies able to show that they had three years of supply on hand. Those regulations had been set to expire at the end of the month.

Statewide water use for December 2016 was 20.6 percent lower than December 2013 levels, and cumulative savings from June 2015 through December 2016 were 22.5 percent, according to the board.

Just a couple of weeks ago, it was determined that, for the first time in three years, no part of the state was experiencing "exceptional drought," the worst of four drought categories. According to the U.S. Drought Monitor, less than 1 percent of the state is in "extreme drought," concentrated in southern Santa Barbara County and central Ventura County, and 11 percent is in "severe drought." Less than half the state is experiencing any drought at all, down from 95 percent a year ago.

Aside from the state's command-and-control tactics, and the question of whether restrictions are still necessary, the regulations also have other damaging effects. Many of the water agencies have voiced concerns that maintaining the restrictions while drought conditions have eased and reservoirs and snowpacks remain higher than normal could lead to a "boy who cried wolf" problem, damaging agencies' credibility with consumers.

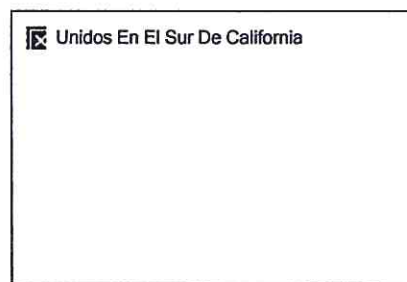

Unidos En El Sur De California
714-796-4301

Riverside Yellow Pages

THINGS TO DO

Most Popular Events See All



ian
Center



Zucchero
Mar 18
Morongo Casino, I

“We just encourage the state to go ahead and let the word ‘emergency’ mean something, mean something serious, so that we can use it again,” Dave Bolland, director of state regulatory relations for the Association of California Water Agencies, told the State Water Board at its meeting.

800-514-7253

ADVERTISE YOUR JOB OPENING HERE

Moreover, as the San Diego County Water Authority noted, the restrictions have made it more difficult to attract and retain businesses.

Lest there be any doubt that control is a key factor at play here, Gov. Brown has directed the State Water Board to develop permanent conservation rules, including caps on indoor and outdoor water use, for implementation likely beginning next year.

Taxpayers have authorized tens of billions of dollars in water bonds over the past couple of decades, but we have precious little to show for it besides unnecessary pork-barrel projects and programs unrelated to actual infrastructure, such as land conservancy purchases, funding for parks and nature education facilities like museums and aquariums and programs for “sustainable communities.” Rather than micromanaging our landscaping and car washing behaviors, the state should get serious about increasing water storage capacity and other needed infrastructure.

Sign up to get breaking news updates delivered to your inbox.

Enter your email address

Sign up

WRITE A LETTER TO THE EDITOR: Letters to the Editor: E-mail to letters@pe.com. Please provide your name, city and telephone number (telephone numbers will not be published). Letters of about 200 words will be given preference. Letters will be edited for length, grammar and clarity.

DIGITAL & DRIVEWAY DELIVERY - 50% OFF

MORE FROM OPINION

Time for U.S. foreign-affairs bureaucracy to move past divisions

Harada House a witness to history, hope for better future

Letters: State’s retired teachers earned their pensions

COMMENTS | PRINT | EMAIL | SHARE

FROM AROUND THE WEB

selected for you by a sponsor

[Subscribe Today](#) | [Customer Service](#) | [P-Edition](#) | [Advertise](#) | | [Top Workplaces](#) | [UnidosSC.com](#) | [Weather](#)
[News](#) | [Sports](#) | [Entertainment](#) | [Business](#) | [Life](#) | [Opinion](#) | [Blogs](#) | [Cannifornian](#) | [Obits](#) | [Press-Enterprise Rewards](#)

[CARS](#)
[JOBS](#)
[HOMES](#)
[DEALS](#)
[CLASSIFIEDS](#)

[City News](#) | [Politics](#) | [Topics](#) | [Environment](#) | [Education](#) | [Announcements](#) | [Traffic](#) | [Photos](#) | [Blogs](#)



ENTERTAINMENT
Ritual Brewing Co. in Redlands marks 'Fat Hog Tuesday'



NEWS
Stranded hikers escorted down from Mount San Jacinto



SPORTS
High school scoreboard: Monday, February 27



NEWS
'House Hunters' episode film in Hemet set to air

NEWS

Riverside County water supplier ditches most restrictions

Water bills may go down after Eastern Municipal Water District restores pre-drought emergency order rates for excessive or wasteful use

[Tweet](#) [Email](#) [Share](#)

By **SUZANNE HURT** / STAFF WRITER
 Published: Feb. 15, 2017 5:57 p.m.



FRANK BELLINO, STAFF PHOTOGRAPHER

Eastern Municipal Water District dropped most water restrictions Wednesday – moving from measures taken to meet the state’s mandatory conservation orders to encouraging voluntary savings among customers.

While state bans on wasteful water use remain, the district board voted unanimously to end its own restrictions and return the water rate structure to pre-drought emergency order levels after supplies increased following heavy rain and snowfall, especially

in Northern California.

Western Riverside County remains in a moderate drought.

Since June 1, 2015, the district’s customers saved 28,000 acre-feet of water, or nearly 90 million gallons, over 2013 use – roughly what 56,000 households use in a year, said Eastern Municipal spokesman Kevin Pearson.

“Our customers stepped up,” he said. “The time is right for those restrictions to be eased.”

The district provides water to about 795,000 people living and working in a 555-square-mile area from Moreno Valley to Temecula, San Jacinto and Hemet.

On Feb. 8, the State Water Resources Control Board extended an amended statewide emergency water conservation regulation for 270 days, despite many water suppliers’ pleas for an end to the regulation.

The district board took action so quickly partly to maintain public trust, so customers know there’s an actual emergency the next time the district takes steps under its water shortage contingency plan, Pearson said.

Unidos En El Sur De California

Unidos En El Sur De California
714-796-4301

Riverside Yellow Pages

THINGS TO DO

Most Popular Events See All

In The Shadows Ent Presents E...

Mar 4
Riverside Municipal Auditorium

Customers will now be charged at a Tier 3 "excessive" rate of \$6.22 per billing unit, or 748 gallons, in most areas if they use 101 percent to 150 percent of their water budget, and a Tier 4 "wasteful" rate of \$11.38 per billing unit over 150 percent. Tier 3 rates had been suspended since June 2015.

Contact the writer: 951-368-9444 or shurt@scng.com

Assistant Director of Nurses

Riverside Healthcare Center

Riverside Behavioral Healthcare Center is an American Healthcare Association National Award Winning Mental Health facility. We are seeking a new Assistant Director of Nurses to join our amazing team. Riverside Behavioral Healthcare Center is a 120 bed locked mental health care facility providing effective care to adults 18-64



Sign up to get breaking news updates delivered to your inbox.

Sign up

DIGITAL & DRIVEWAY DELIVERY - 50% OFF

MORE FROM PERRIS



Invasive mussel larvae found in San Bernardino County to Perris pipeline



4 arrested after body of San Bernardino man found buried at marijuana farm



Suspect found dead in burned Riverside house told fiancee he didn't shoot at police

[COMMENTS](#) | [PRINT](#) | [EMAIL](#) | [SHARE](#)

FROM AROUND THE WEB

selected for you by a sponsor



Homeowners Should Claim Their \$4264 In February.

FetchRate



Short Term Loans For Bad Credit

Personal Loans



Teen Vanishes On Spring Break. But 10 Years Later, Police Uncover Truth

LifeDaily

8. MANAGER'S REPORT:

9. INSPECT NEW TYPE I ENGINE IN SERVICE AT RUBIDOUX CSD
FIRE STATION: **DM 2017-08**

Rubidoux Community Services District

Board of Directors
Christopher Barajas
Armando Muniz
Bernard Murphy
F. Forest Trowbridge
Ruth Anderson Wilson



Secretary-Manager
David D. Lopez

Water Resource Management Refuse Collection Street Lights Fire / Emergency Services Weed Abatement

DIRECORS MEMORANDUM 2017-08

March 2, 2017

To: Rubidoux Community Services District
Board of Directors

Subject: Inspect New Type I Engine in Service at Rubidoux CSD Fire Station

BACKGROUND:

In 2016, the Rubidoux Community Services District included (amended) in the Fire Services Agreement with the County of Riverside / Cal Fire a Fire Engine lease provision. Due to our annual incident calls (2,600+), a typical fire engine has a reliable service cycle of 10 to 15 years. At an annual lease cost of \$25,331.00, the decision to lease fire engines makes sound fiscal sense for our District.

This afternoon Chief Lanzas and Cal Firefighters will be present along with the new Type I Engine to review with the Board of Directors.

RECOMMENDATION:

No recommendation necessary.

Respectfully,

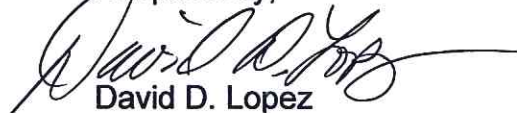

David D. Lopez
Secretary-Manager

Attachment: Photo

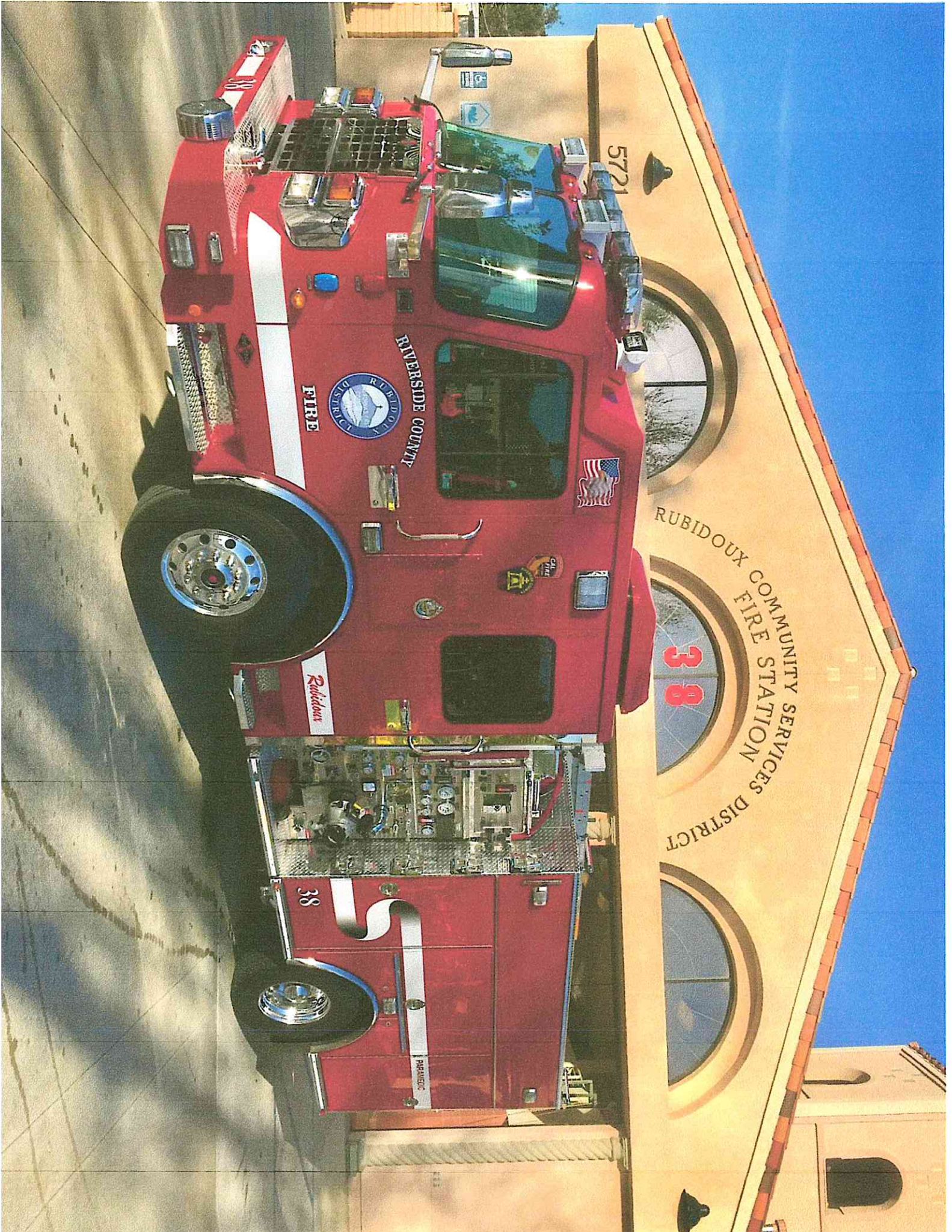

5721

RIVERSIDE COUNTY
FIRE



Rubidoux

RUBIDOUX COMMUNITY SERVICES DISTRICT
RUBIDOUX FIRE STATION
38

38

RUBIDOUX

10. CONSIDERATION TO AWARD THE PURCHASE OF TWO (2)
UTILITY VEHICLES FOR WATER OPERATIONS: **DM 2017-09**

Rubidoux Community Services District

Board of Directors

Christopher Barajas
Armando Muniz
Bernard Murphy
F. Forest Trowbridge
Ruth Anderson Wilson



Secretary-Manager

David D. Lopez

Water Resource Management Refuse Collection Street Lights Fire / Emergency Services Weed Abatement

DIRECTORS MEMORANDUM 2017-09

March 2, 2017

To: Rubidoux Community Services District
 Board of Directors

Subject: Award the Purchase to Two (2) Water Department Utility Vehicles

BACKGROUND:

On February 22, 2017, the District received three (3) sealed bids for two (2) Water Department vehicles; Crest Chevrolet, Raceway Ford and Sunrise Ford. Attached for the Board of Director's consideration are two (2) vehicle bid summaries for a Water Department Trucks w/utility beds.

The Water Department is cycling out of service a 2009 Ford F150 truck with 52,000± miles. The above truck will be replaced by a submitted bid from Crest Chevrolet in San Bernardino with a new 2017 3/4 ton utility bed truck. In review of the attached summary's, Crest Chevrolet submitted the lowest total bid amount of \$27,604.60 (includes taxes, extended warranty and trade-in value of \$8,700.00 for the 2009 F150 Ford).

The second bid summary identifies another 2017 3/4 truck w/utility bed to be replacing a 2011 Ford ¾ ton Utility bed Truck with 72,000± miles. Again, the lowest bid was submitted by Crest Chevrolet with a total bid amount of \$25,904.51 (includes taxes, extended warranty and trade-in value of \$10,400.00).

Both vehicles were scheduled for cycling out this year and are budgeted in the Water Department's line item No. 41 for a total amount of \$50,000.00 (See 2016/2017 water budget attached hereto).

RECOMMENDATION:

Staff has reviewed and compiled the attached bid summaries and recommends the following to the Rubidoux Community Services District Board of Directors:

- 1) Recognize the Bid for a 2017 ¾ ton utility bed truck submitted by Crest Chevrolet for a total amount of \$27,604.60 as the lowest responsive bid.
- 2) Surplus the 2009 F150 truck, Vin No. 1FTMF1CWOAKB37077 and accept Crest Chevrolet's trade-in offer of \$8,700.00 for subject vehicle.
- 3) Recognize Crest Chevrolet's total bid amount of \$25,904.59 for a 2017 ¾ ton utility bed truck as the lowest responsive bid submitted.
- 4) Surplus the 2011 Ford F250 truck, VIN No. 1FDBF21A63BEA85357 and accept Crest Chevrolet's trade-in offer of \$10,400.00 for subject vehicle.
- 5) Adjust the Water Budget Line No. 41 to from \$50,000.00 to \$53,600.00 for the purchase of the above utility trucks.

Respectfully,

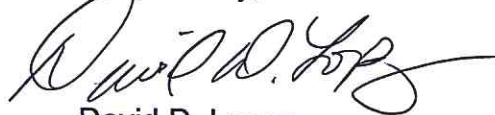

David D. Lopez
Secretary-Manager

Attachments: Bid Summaries
2016/17 Water Fund Budget

MEMORANDUM

DATE: February 24, 2017

TO: David D. Lopez, General Manager

FROM: Brian Jennings, Manager Budgeting and Accounting

SUBJECT: Utility Department Vehicle Replacement Truck Bid Results and Recommendation

On Wednesday, February 22, 2017, staff opened sealed bids for Two (2) New Trucks.

Truck #1 is a Two-Wheel Drive, Utility Bed Truck, V8 with Automatic Transmission.

Truck #2 is a Two-Wheel Drive, Utility Bed Truck, V8 with Automatic Transmission.

We requested bids from 6 different dealers for each vehicle.

The results are shown below. Additionally, we requested an additive bid for including a minimum 5-year/150,000 mile extended warranty on the trucks which have been included in the summary.

Rank	Dealer	Truck #1 Utility Bed			Total Bid	Model Year	In Stock	Meets Specs	Delivery
		New Truck Bid	Warranty	Trade-In					
1	Crest Chevrolet - San Bern.	\$ 31,968.30	\$1,850.00	\$(8,700.00)	\$27,604.60	2017	Yes	Meets Specs	Meets
2	Sunrise Ford - Fontana	\$ 30,039.65	\$2,265.00	\$(6,000.00)	\$28,756.67	2017	Yes	Meets Specs	Meets
3	Raceway Ford - Riverside	\$ 30,272.82	\$3,315.00	\$(7,000.00)	\$29,028.91	2017	Yes	Meets Specs	Meets
	Riverside Chevrolet	No Bid	No Bid	No Bid	No Bid	No Bid	No Bid	No Bid	No Bid
	Moss Dodge - San Bern.	No Bid	No Bid	No Bid	No Bid	No Bid	No Bid	No Bid	No Bid
	Browning Dodge - Norco	No Bid	No Bid	No Bid	No Bid	No Bid	No Bid	No Bid	No Bid

*The low bidder for Truck #1 is Crest Chevrolet, It is my recommendation that we issue a Purchase Order to Crest Chevrolet for the amount of \$27,604.60 for 1 (One) Two-Wheel Drive, Utility Bed Truck, V8 with Automatic Transmission and meets specifications.

Recommend also that Crest Chevrolet take the following vehicle in trade:

- 2009 Ford F150 Pickup with approximately 52,000 miles VIN# 1FTMF1CW0AKB37077

Delivery is approximately 30 days from award date.

Rank	Dealer	Truck #2 Utility Bed			Total Bid	Model Year	In Stock	Meets Specs	Delivery
		New Truck Bid	Warranty	Trade-In					
1	Crest Chevrolet - San Bern.	\$ 31,968.30	\$1,850.00	\$(10,400.00)	\$25,904.59	2017	Yes	Meets Specs	Meets
2	Raceway Ford - Riverside	\$ 30,272.82	\$3,315.00	\$(10,000.00)	\$26,028.91	2017	Yes	Meets Specs	Meets
3	Sunrise Ford - Fontana	\$ 30,039.65	\$2,265.00	\$(8,000.00)	\$26,638.92	2017	Yes	Meets Specs	Meets
	Riverside Chevrolet	No Bid	No Bid	No Bid	No Bid	No Bid	No Bid	No Bid	No Bid
	Moss Dodge - San Bern.	No Bid	No Bid	No Bid	No Bid	No Bid	No Bid	No Bid	No Bid
	Browning Dodge - Norco	No Bid	No Bid	No Bid	No Bid	No Bid	No Bid	No Bid	No Bid

*The low bidder for Truck #2 is Crest Chevrolet. It is my recommendation that we issue a Purchase Order to Crest Chevrolet for the amount of \$25,904.59 for 1 (One) Two-Wheel Drive, Utility Bed Truck, V8 with Automatic Transmission and meets specifications.

Recommend also that Crest Chevrolet take the following vehicle in trade:

- 2011 Ford F250 Utility Bed with approximately 72,000 miles VIN# 1FDBF21A63BEA85357

Delivery is approximately 30 days from award date.

Total purchase price for the two above vehicles is \$53,509.19.

Rubidoux Community Services District

WATER FUND SUMMARY

WATER FUND SUMMARY						
Line #	Income/Revenue General Ledger Description	Month of	Year to Date	Budget	Estimated	Proposed
		Actual Mar '16	Actual Total	Fiscal Year FY 15/16	Fiscal Year End June '16	Revenue FY 16/17
1	SALES RESIDENTIAL	\$ 210,496	\$ 2,146,002	\$ 2,715,347	\$ 2,861,336	\$ 3,047,300
2	SALES COMMERCIAL	63,036	734,800	1,143,109	979,733	1,043,400
3	PLANNED FIELD/ADMIN BLDG	5,965	47,718	89,000	71,577	89,000
4	INTERAGENCY SALES (Marginal Cost)	72,233	563,959	168,000	108,354	110,000
6	LATE CHARGES	10,549	107,231	155,000	142,975	155,000
7	SERVICE & RECONNECT CHARGES	1,400	14,620	25,000	19,493	25,000
8	METER REPLACEMENT (SALES)	260	8,610	5,000	8,900	8,000
9	INTEREST INCOME	-	11,794	12,000	15,725	15,000
10	MISCELLANEOUS INCOME	149	30,984	40,000	41,312	40,000
12	OPERATING RESTRICTED	-	-	2,802,589	2,834,396	3,500,000
13	OPERATING RESTRICTED (Interagency Transfer)	-	-	1,002,000	665,604	670,000
14	COP TRANSFER	-	-	-	-	500,000
15	WATER OPERATIONS CARRYOVER	-	-	1,147,643	73,741	(91,379)
16	Total Income & Revenue for Budget	\$ 364,088	\$ 3,665,718	\$ 9,304,688	\$ 7,823,147	\$ 9,111,321
Line #	Expense General Ledger Description	Month of	Year to Date	Budget	Estimated	Proposed
		Actual Mar '16	Actual Total	Fiscal Year FY 15/16	Fiscal Year End June '16	Expenses FY 16/17
17	SALARIES EXPENSE	\$ 80,445	\$ 748,486	\$ 1,010,900	\$ 997,981	\$ 1,029,100
18	CASH BENEFIT EXPENSE	7,704	73,350	97,000	97,800	97,000
19	PAYROLL TAX EXPENSE	6,988	71,830	98,000	95,773	98,000
20	HEALTH & RETIREMENT EXPENSE	43,283	460,970	585,000	534,627	585,000
21	PUMP ENERGY COSTS	27,634	373,213	505,000	497,617	513,000
22	WATER ANALYSES EXPENSE	4,770	36,190	59,000	48,253	55,000
23	BAD DEBT EXPENSE	-	27,256	65,000	36,341	45,000
24	OPERATING SUPPLIES/EQUIP RENT	5,088	131,492	175,000	175,323	175,000
25	N03 Plnt - Supplies and Energy	6,672	127,917	250,000	170,556	200,000
26	R & M VEHICLE	2,303	26,358	25,000	29,200	25,000
27	R & M EQUIPMENT, HEAVY	303	9,249	10,000	11,500	10,000
28	R & M WATER SYSTEM	11,363	97,885	100,000	130,513	150,000
29	R & M FIELD OFFICE	692	2,604	7,500	3,472	7,500
30	CHEMICAL/MINERAL SUPPLIES	2,040	29,391	50,000	39,188	50,000
31	GAS ALLOWANCE	450	4,050	7,000	5,400	7,000
32	REGULATORY FEE/STATE	-	5,689	20,000	7,585	20,000
33	CLOTHING/SHOE EXPENSE	178	2,121	7,500	2,828	7,500
34	CONSERVATION EDUC PROGRAM	-	-	5,000	-	5,000
35	CROSS CONNECTION	1,117	1,117	5,000	1,489	5,000
36	UTILITIES/TELEPHONE/GASOLINE	2,923	36,515	85,000	48,687	55,000
37	DUES/SUBSCRIP/EDUC/MILE/SEMNRS	2,768	5,025	12,000	6,700	12,000
38	PERMITS/ASSOCIATION DUES	-	21,322	18,000	25,800	26,000
39	LIABILITY INSURANCE	34	30,974	60,000	41,299	50,000
40	WORKERS COMP INSURANCE	2,706	27,452	50,000	36,603	45,000
41	FLEET REPLACEMENT	-	32,702	50,000	32,702	50,000
42	ATTORNEY FEES	-	-	5,000	-	5,000
43	ENGINEERING FEES	2,808	25,057	43,000	33,409	43,000
44	LOSS CLAIMS	-	-	20,000	-	20,000
45	PUBLICATION OF PUBLIC NOTICES	-	-	3,500	500	3,500
46	MISCELLANEOUS EXPENSE	-	-	5,000	1,000	5,000
47	ACCRUED EMP BENE (buyout)	-	39,071	49,000	39,071	49,000
48	GIS/MAPPING (Maintenance)	-	1,572	2,500	1,572	2,500
49	MASTER PLAN UPDATE	-	1,780	25,000	1,780	Complete
50	AMR EQUIPMENT (RADIO READ)	-	-	50,000	-	50,000
51	AERIAL PHOTO	-	-	7,500	-	3,500
52	METER READING HANDHELDS	-	7,753	7,900	7,753	Complete
53	GENERATOR WELL #8	-	65,583	60,000	65,583	Complete
54	URBAN WATER MGMT PLAN (UWMP)	-	23,436	65,000	31,331	40,000
55	ADMIN GENERAL EXPENSE	137,500	412,500	550,000	550,000	600,000
56	MN PLANT SRL	-	364,194	364,194	364,194	364,194
57	SRL CAPITAL RPLCMT (Contractual Obligation)	-	91,000	91,000	91,000	91,000
58	PLANNED FIELD/ADMIN BLDG	5,965	47,718	89,000	71,577	89,000
59	SIGNBOARDS (DM 2015-43)	-	68,418	-	68,418	Complete
60	E-CITIZEN SOFTWARE APP (DM 2016-56)	-	10,100	-	10,100	Complete
61	BACKHOE	-	-	-	-	80,000
62	OPERATING RESTRICTED (Interagency Transfer)	-	-	-	-	558,700
63	WATER OPERATION RESTRICTED	-	-	3,804,589	3,500,000	3,611,300
64	CONTINGENCY: UNENCUMBERED	-	-	705,605	(91,379)	173,527
65	Total Expenditures for Budget	\$ 355,734	\$ 3,541,340	\$ 9,304,688	\$ 7,823,147	\$ 9,111,321

Rubidoux Community Services District

Board of Directors

Christopher Barajas
Armando Muniz
Bernard Murphy
F. Forest Trowbridge
Ruth Anderson Wilson

Secretary-Manager

David D. Lopez

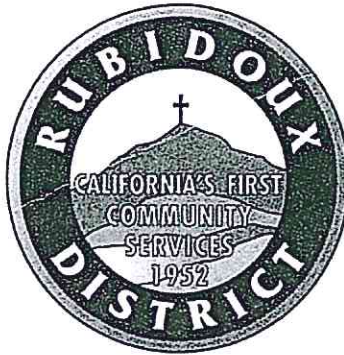

CREST
CHEV

USPS. *BJ*

Water Resource Management Refuse Collection Street Lights Fire & Emergency Services Weed Abatement

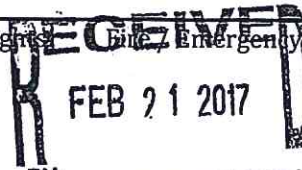

February 8, 2017

SUBJECT: Request for Quotation - Two (2) New 2016 or 2017, ¾ Ton, 9,000 GVW or equivalent, 8 Ft Utility Bed Trucks, Two-Wheel Drive, V8, Automatic.

Dear Sir or Madame:

The Rubidoux Community Services District (District) is requesting a proposal for the purchase of two (2) new (2016 or 2017 Model Year) Two-Wheel Drive, V8, Automatic, ¾ Ton Utility Bed Trucks. The District, a public agency located in the County of Riverside, California, is eligible for all Standard Governmental Service Fleet Pricing and Warranties.

NOTE: IT IS THE INTENT OF THE DISTRICT TO TAKE DELIVERY "OFF THE LOT" RATHER THAN ORDER THE VEHICLE.

Winning bidder must be able to deliver the vehicle within 2 weeks or earlier of the award date of March 3, 2017. Delivery date of March 17, 2017 or earlier.

Dealers should submit Bids to Rubidoux Community Services District, based on the attached specifications, no later than 4:00 PM on Wednesday, February 22, 2017.

Should you have any questions, please do not hesitate to contact me directly at the District office.

Sincerely,

Brian Jennings
Manager Budgeting and Accounting

Attachments:

Minimum Specification Sheet(s) Truck #1 and Truck #2
Quote Sheet(s) Truck #1 and Truck #2

RUBIDOUX COMMUNITY SERVICES DISTRICT

3590 Rubidoux Blvd. P.O. Box 3098

Jurupa Valley, CA 92519

(951) 684-7580 - Fax (951) 369-4061

Utility Bed Truck # 1

Vehicle Specifications

NOTE: Vendor must indicate either "Yes" or "No" in the columns labeled "Meets Spec".

	<u>Meets Spec.</u>	<u>Comments</u>
Model:		
8 FT Utility Bed Truck – 2 Door Regular Cab 2WD, 3/4-Ton GVW 9,000 or Similar	YES	
Color:		
Exterior - White	YES	
Interior - Any	YES	
Cab:		
Seats – Vinyl/Cloth	YES	
Flooring - Vinyl	YES	
Engine:		
V8 Gasoline, 6.0 Liter 360HP. 380lbs torque 6.2 L, 430 Foot lbs Torque or greater EFI V8	EXCEPTION	
Transmission:		
5 or 6-Speed Automatic With Overdrive HD	YES	6SPD.
Electrical:		
Cold Cranking - 650 Amps or better Reserve Capacity - 115 Minutes or better		
Cooling System:		
Heavy Duty Radiator	YES	
Frame:		
All-Welded Ladder Type	YES	
Suspension:		
Front:		
Heavy Duty - Independent Coil Springs	YES	
Rear:		
Heavy Duty - Semi-Elliptic, Two-Stage, Multi-Leaf	YES	
Axles:		
Limited Slip, <u>Single Rear Wheels</u>	YES	

Tires:

LT245/75R-17/D All Season Black wall (or better)	YES YES YES	
Full Size Spare Tire W/ Steel Wheel		
17" Silver Painted Steel Wheel W/ Argent Center Cap		
Under-Body Mounted Locking Winch-Type Spare Tire Carrier		

Brakes:

Heavy Duty - Hydraulic Power 4 Wheel Disc Brakes	YES	
---	-----	--

Fuel Tank:

Capacity - 30 Gallons or greater		
----------------------------------	--	--

Battery:

HD 600 CCA Battery or better	YES	
------------------------------	-----	--

Radio

AM/FM	YES	
-------	-----	--

Air Conditioning

Factory Air Conditioner	YES	
-------------------------	-----	--

Safety

4-Wheel Anti-Lock Brake System	YES.	
Driver & Front Passenger Airbags With Passenger Side Deactivation Switch		
Manual Lap/Shoulder Safety Belts, Outboard Seat Position		
Manual Lap Safety Belts, Center Seat Position		
Head Restraints At Outboard Seating Positions		
Daytime Running Lamps		

	OR Equal	Meets Spec	Comments
Utility Body	See Attached (Last Pages) – <u>Scelzi Body/Harbor Trade Master or Equal</u>		
Locks	Internal Master Locks, Push Pull		
Paint	Paint Factory White		
Bumper	Recessed Bumper (Weight Certificate)		
Lights	Legal Light Package With 7 wires Harness/ Wiring		
Trailer Hitch	Heavy Duty Tow Package		
Lid Covers	Aluminum or Stainless Open-Top Model Appearance Package		
Vise Brackets	Mounted On Left (Driver Side)		
	<p>Royal Truck Body SEE ATT SHEET.</p>		

Rubidoux Community Services District is a public agency located in the County of Riverside, California, and is eligible for all Standard Governmental Service Fleet Pricing and Warranties.

Additional equipment and/or upgraded modification should be listed as a separate item to allow an accurate and effective evaluation of submitted bids. All modifications to the minimum specifications, as stated above, shall be clearly identified. The quote should have 150,000 mile, 5 year, 6,000 engine hour extended warranties that should also be included in the submitted proposal and options for the vehicle.

The vehicle quoted price shall include all applicable state and local taxes, licenses, dealer transportation and preparation fees. Vehicles shall be "Highway Ready" with registration plates being filed "Exempt" by the dealer(s) with the Department of Motor Vehicles.

The above vehicles shall be fully fueled and lubricated.

RUBIDOUX COMMUNITY SERVICES DISTRICT

QUOTATION REQUEST

The Rubidoux Community Services District is requesting quotations to furnish and deliver equipment as described per attached District standard vehicle specification. Note: The total price quoted shall include all applicable taxes and delivery cost. "E" license are required.

<u>Term</u>	(1) Model Year 2016 or 2017, 3/4 Ton 9,000 GVW or equivalent 8 FT Utility Bed Truck (Truck #1)	PRICE \$ <u>31,968.30</u>
<u>Warranty</u>	150,000 Miles/5 Year; 6,000 Engine Hour (Extended Warranty)	\$ <u>1850.—</u>
	<i>GM EXT WARRANTY 5 YRS OR 120,000 MILES POWER TO BUYER & DEDUCTABLE.</i>	df TAX \$ <u>2477.54</u> TIRE TAX <u>8.75</u>
<u>Trade In Item</u>	2009 Ford F150 PickUp VIN # 1FTMF1CW0AKB37077 Approximately 52,000 miles	\$(<u>8700.—</u>) TOTAL \$ <u>27,604.59</u>

The intended target vehicle is a ¾ ton, 4x2 Truck, V8, automatic. It is preferred that the winning bidder be able to deliver the vehicle within 2 weeks or earlier of the award date. Otherwise bidder need provide best estimate of delivery date in bid quote.

The equipment quoted shall be furnished in compliance with the State of California Air Resource Board standards and as comparable to the attached specification sheets **for delivery by March 17, 2017 or earlier.**

Proposals should arrive at the District office no later than 4:00 pm, Wednesday, February 22, 2017. It is anticipated that the District shall award the contract at the regularly scheduled meeting of the Board of Directors, March 2, 2017. The District will issue to the awarded dealer a Purchase Order for the vehicle the day following Board approval. Upon vehicle delivery

TRUCK # 1

and acceptance by the District, payment shall be made in full to the selected dealer within thirty (30) calendar days.

The District reserves the right to reject any and all bids received.

Written proposals should be submitted to: Attn: Brian Jennings
Rubidoux Community Services District,
3590 Rubidoux Blvd.
Jurupa Valley, California 92509

Faxed proposals may be transmitted to RCSD Attn: Brian Jennings at (951) 369-4061.

Said envelope shall also contain the following in the lower left-hand corner thereof:

Proposal of _____ (Name of Bidder) _____

For: One (1) Model Year 2016 or 2017, 3/4 Ton, 8 Ft Utility Truck Bid (Truck #1)

Signed:

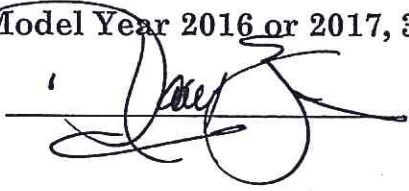

Company:

CREST CHEVROLET

Title:

FLEET SALES MGR.

Address:

909 W. 21st

Date:

2/17/2017

City:

SAN BERNARDINO, CA 92405

Estimated Delivery Date: APPOX 30 DAYS FROM AWARD DATE

RUBIDOUX COMMUNITY SERVICES DISTRICT

3590 Rubidoux Blvd. P.O. Box 3098

Jurupa Valley, CA 92519

(951) 684-7580 - Fax (951) 369-4061

Utility Bed Truck # 2

Vehicle Specifications

NOTE: Vendor must indicate either "Yes" or "No" in the columns labeled "Meets Spec".

Meets Spec	Comments
------------	----------

Model:

8 FT Utility Bed Truck – 2 Door Regular Cab 2WD, 3/4-Ton GVW 9,000 or Similar	YES	
--	-----	--

Color:

Exterior - White	YES	
Interior - Any	YES	

Cab:

Seats – Vinyl/Cloth	YES	
Flooring - Vinyl	YES	

Engine:

V8 Gasoline, 6.0 LITER 360 H.P. 380 lbs torque 6.2 L, 430 Foot lbs Torque or greater EFI V8	EXCEPTION	
--	-----------	--

Transmission:

5 or 6-Speed Automatic With Overdrive HD	YES	6 SPD
--	-----	-------

Electrical:

Cold Cranking - 650 Amps or better Reserve Capacity - 115 Minutes or better	YES	
--	-----	--

Cooling System:

Heavy Duty Radiator	YES	
---------------------	-----	--

Frame:

All-Welded Ladder Type	YES	
------------------------	-----	--

Suspension:

Front:

Heavy Duty - Independent Coil Springs	YES	
---------------------------------------	-----	--

Rear:

Heavy Duty - Semi-Elliptic, Two-Stage, Multi-Leaf	YES	
---	-----	--

Axles:

Limited Slip, Single Rear Wheels	YES	
----------------------------------	-----	--

Tires:

LT245/75R-17/D All Season Black wall (or better)	YES	
Full Size Spare Tire W/ Steel Wheel		
17" Silver Painted Steel Wheel W/ Argent Center Cap		
Under-Body Mounted Locking Winch-Type Spare Tire Carrier		

Brakes:

Heavy Duty - Hydraulic Power 4 Wheel Disc Brakes	YES	
---	-----	--

Fuel Tank:

Capacity - 30 Gallons or greater	YES	
----------------------------------	-----	--

Battery:

HD 600 CCA Battery or better	YES	
------------------------------	-----	--

Radio

AM/FM	YES	
-------	-----	--

Air Conditioning

Factory Air Conditioner	YES	
-------------------------	-----	--

Safety

4-Wheel Anti-Lock Brake System	YES	
Driver & Front Passenger Airbags With Passenger Side Deactivation Switch		
Manual Lap/Shoulder Safety Belts, Outboard Seat Position		
Manual Lap Safety Belts, Center Seat Position		
Head Restraints At Outboard Seating Positions		
Daytime Running Lamps		

	OR Equal	Meets Spec	Comments
Utility Body	See Attached (Last Pages) - <u>Scelzi Body/Harbor Trade Master or Equal</u>		
Locks	Internal Master Locks, Push Pull		
Paint	Paint Factory White		
Bumper	Recessed Bumper (Weight Certificate)		
Lights	Legal Light Package With 7 wires Harness/ Wiring		
Trailer Hitch	Heavy Duty Tow Package		
Lid Covers	Aluminum or Stainless Open-Top Model Appearance Package		
Vise Brackets	Mounted On Left (Driver Side)		
<p><i>ROYAL TRUCK BODY</i> <i>SEE ATT SHEET.</i></p>			

Rubidoux Community Services District is a public agency located in the County of Riverside, California, and is eligible for all Standard Governmental Service Fleet Pricing and Warranties.

Additional equipment and/or upgraded modification should be listed as a separate item to allow an accurate and effective evaluation of submitted bids. All modifications to the minimum specifications, as stated above, shall be clearly identified. The quote should have 150,000 mile, 5 year, 6,000 engine hour extended warranties that should also be included in the submitted proposal and options for the vehicle.

The vehicle quoted price shall include all applicable state and local taxes, licenses, dealer transportation and preparation fees. Vehicles shall be "Highway Ready" with registration plates being filed "Exempt" by the dealer(s) with the Department of Motor Vehicles.

The above vehicles shall be fully fueled and lubricated.

RUBIDOUX COMMUNITY SERVICES DISTRICT

QUOTATION REQUEST

The Rubidoux Community Services District is requesting quotations to furnish and deliver equipment as described per attached District standard vehicle specification. Note: The total price quoted shall include all applicable taxes and delivery cost. "E" license are required.

<u>Term</u> (1) Model Year 2016 or 2017, 3/4 Ton 9,000 GVW or similar 8 FT Utility Bed Truck (Truck #2)	PRICE \$ <u>31,968.30</u>
<u>Warranty</u> 150,000 Miles/5 Year; 6,000 Engine Hour (Extended Warranty) GM EXT WARRANTY 5YR OR 120,000 MILES BUMPER/BUMPER & DEDUCTABLE	\$ <u>1850.-</u> TAX \$ <u>2477.54</u> TIRE TAX <u>8.75</u>
<u>Trade In Item</u> 2011 Ford F250 Utility Bed VIN # 1FDBF21A63BEA85357 Approximately 72,000 miles	\$(<u>10,400.-</u>) TOTAL \$ <u>25,904.59</u>

The intended target vehicle is a ¾ Ton, 4x2 Truck, V8, automatic. It is preferred that the winning bidder be able to deliver the vehicle within 2 weeks or earlier of the award date. Otherwise bidder need provide best estimate of delivery date in bid quote.

The equipment quoted shall be furnished in compliance with the State of California Air Resource Board standards and as comparable to the attached specification sheets **for delivery by March 17, 2017 or earlier.**

Proposals should arrive at the District office no later than 4:00 pm, Wednesday, February 22, 2017. It is anticipated that the District shall award the contract at the regularly scheduled meeting of the Board of Directors, March 2, 2017. The District will issue to the awarded dealer a Purchase Order for the vehicle the day following Board approval. Upon vehicle delivery

TRUCK # 2

and acceptance by the District, payment shall be made in full to the selected dealer within thirty (30) calendar days.

The District reserves the right to reject any and all bids received.

Written proposals should be submitted to: Attn: Brian Jennings
Rubidoux Community Services District,
3590 Rubidoux Blvd.
Jurupa Valley, California 92509

Faxed proposals may be transmitted to RCSD Attn: Brian Jennings at (951) 369-4061.

Said envelope shall also contain the following in the lower left-hand corner thereof:

Proposal of _____ (Name of Bidder) _____

For: One (1) Model Year 2016 or 2017, 3/4 Ton, 8 Ft Utility Truck Bid (Truck #2)

Signed:



Company:

CREST CHEVROLET

Title:

FLEET SALES MGR

Address:

909 W 21st

Date:

2/17/2017

City:

SAN BERNARDINO, CA 92405

Estimated Delivery Date: Approx 30 Days From Award Date.

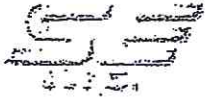

8 ft. Service Body Datasheet

Standard Accessories and Features

- Chrome t-bar handle latches with polished stainless steel pockets and Galvaneal steel locking rods.
- Three point latching system on all compartment doors.
- Full-length, 5/16" stainless steel door shafts and hinge blocks with nylon inserts. On all compartment.
- All hinge blocks fastened with stainless steel mona bolts.
- All compartment doors equipped with barrel locks.
- Gas shocks on open top compartments.
- Seat-beam type tail and clearance lights.
- Gas shocks on all compartment doors.
- Scelzi exclusive door seal.
- All bodies equipped with a six inch step bumper.
- Bodies fastened to frame at six mounting points.
- All seams are caulked with 3M ultra pro seam sealer.
- Complete under sealing of bed and wheel wells. Multiple coats of primer and urethane paint to maintain durability.
- Wiring built as harnesses and run thru loop clamps to prevent chafing and to secure mounting.
- Stainless steel tubing around wheel well openings.
- Self-leveling tailgate with stainless steel cap and guard rail. Diamond plate inner lining.
- *Vise Bracket - Mounted Left (Over the side)*

Material

- Exterior structural body panels.
- Door post: 14 Gauge Galvaneal steel.
- End caps: 14 Gauge Galvaneal steel.
- Back wrapper: 14 Gauge Galvaneal steel.
- Closed tops and open top lids: 16 Gauge Galvaneal steel.
- Flooring: 12 Gauge diamond plate.
- Bulkhead: 14 Gauge Galvaneal steel.
- Interior structural body panels.
- Door skin: 18 Gauge Galvaneal steel.
- Inner door skin: 20 Gauge Galvaneal steel.

Unacceptable Practices and Components

- Body mounting using only four points.
- Clip-in adjustable shelving.
- Single panel doors.
- Wiring running through interior of compartments.
- Shelving made from material other than 16 Gauge Galvaneal steel.
- Piano hinges on compartment doors.

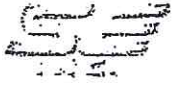

8 ft. Service Body Schematic

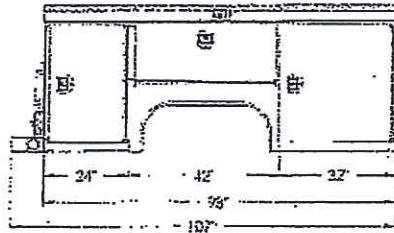
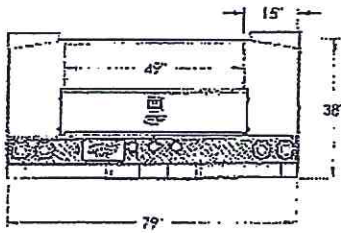
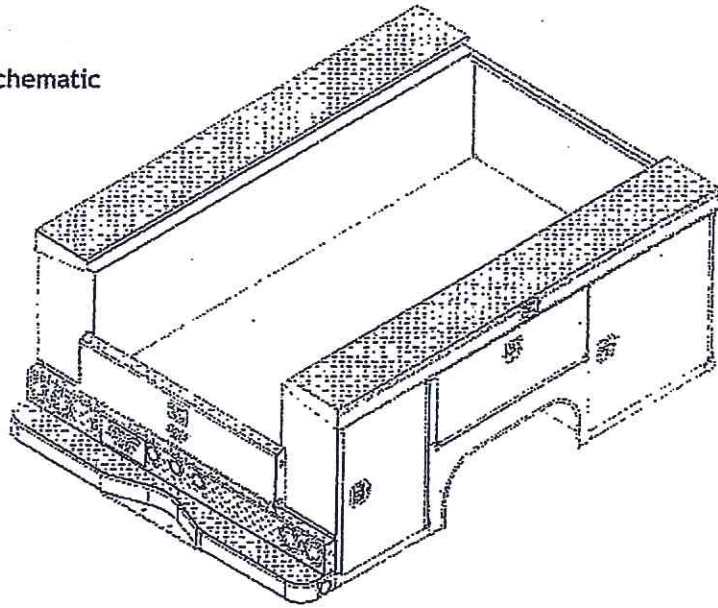

8-ft. TradeMaster

For 56" Cab-to-Axle Trucks with 8600 GVWR Minimum

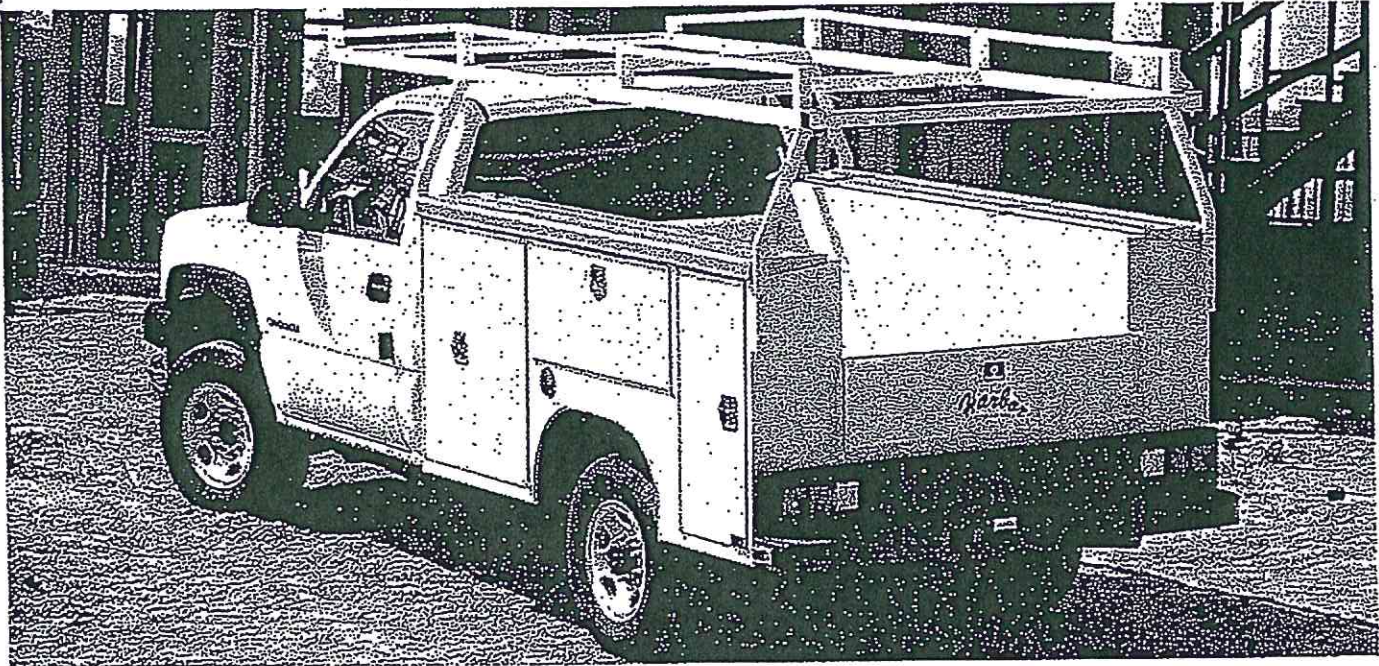

8-FT TRADEMASTER DIMENSIONS

STANDARD OPEN-TOP
VERTICAL SERIES

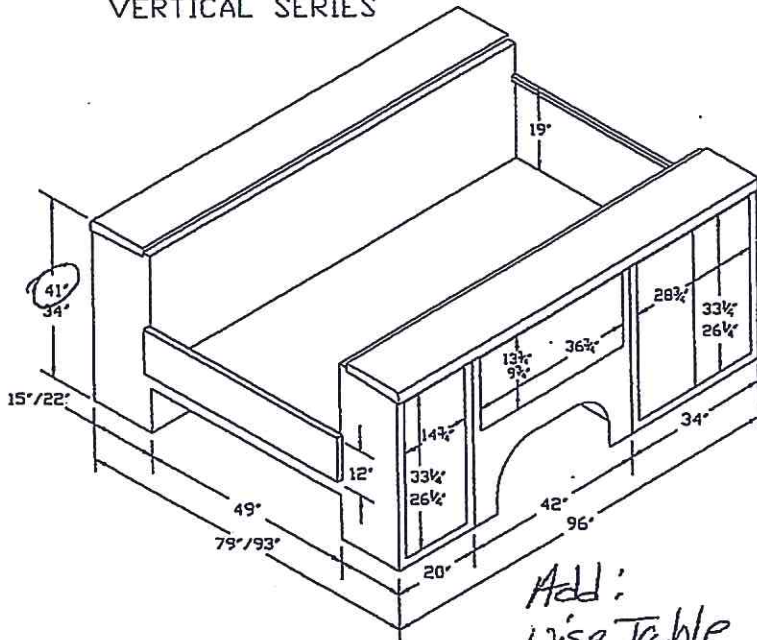

*Add:
Use Table*

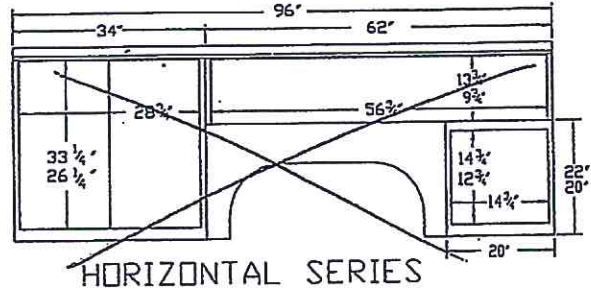

HORIZONTAL SERIES

CLOSED-TOP
MODEL

OPEN-TOP
MODEL

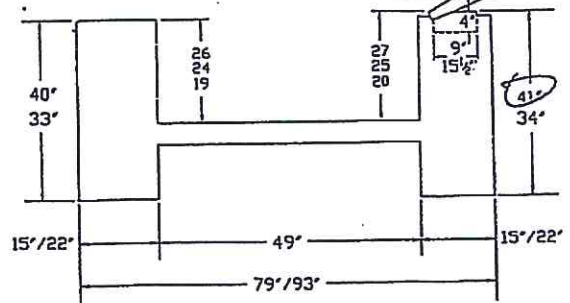

NOTE:

- DOOR COMPARTMENT DIMENSIONS ARE THE CLEAR DOOR OPENING.
- TOP VERTICAL DIMENSIONS ARE STANDARD HEIGHT BODIES
BOTTOM DIMENSIONS ARE LOW PROFILE BODIES

2017 SILVERADO 2500 2WD WT REG CAB GENERAL MOTORS LLC
 GAZ SUMMIT WHITE /V8G
 H2R JET BLACK / DARK ASH RENAISSANCE CENTER
 ORDER NO. TRXD67/TSC STOCK NO. DETROIT MI 48243-1114
 VIN 1GB 0CUE G7 HZ217951 VEHICLE INVOICE 1AD33863266
 *****2540*****

MODEL & FACTORY OPTIONS	MSRP	INV AMT	RETAIL - STOCK
CC25903 SILVERADO 2500 2WD WT REG	33310.00	29812.45	INVOICE 01/17/17
DF2 CAMPER STYLE EXTERIOR MIRRORS, MANUAL	70.00	61.60	SHIPPED 01/17/17
(REPLACES STD/OPT MIRRORS)			EXP I/T 01/30/17
G4A GVW RATING - 9,300 LBS	N/C	N/C	INT COM 01/30/17
IOB CHEVROLET MYLINK AUDIO SYSTEM W/ 7" DIAGONAL COLOR TOUCH ONSTAR(R) INCLUDES 5 YR BASIC PLAN PLUS 6 MTH SERVICE W/ AUTOMATIC CRASH RESPONSE, NAVIGATION & MORE.	435.00	382.80	PRC EFF 01/17/17
INCL: 4G LTE WI-FI (R) HOTSPOT W/ LIMITED DATA TRIAL & MORE (SUBJECT TO TERMS SEE ONSTAR.COM)			KEYS V0227 V0227
JL1 TRAILER BRAKE CONTROLLER	275.00	242.00	MFP-
L96 VORTEC 6.0L V8 SFI GAS ENGINE	N/C	N/C	FAN: 000858926
MYD 6-SPEED AUTOMATIC TRANSMISSION	N/C	N/C	BANK: ALLY - 061
YF5 50-STATE EMISSIONS	N/C	N/C	CHG-TO 59-899
ZHQ 17" ALL-SEASON BW SPARE TIRE	335.00	294.80	SHIP WT: 5127
ZW9 PICKUP BOX DELETE: DELETES PICKUP BOX, TAILGATE LOCKING, REAR BUMPER, AND SPARE TIRE	675.00-	594.00-	HP: 51.2
			GVWR: 9300
			GAWR.FT: 4400
			GAWR.RR: 6200
			NTR: 3/4
			DAN: 2RGS2

TOTAL MODEL & OPTIONS 33750.00 30199.65 ACT 237 31394.65
 DESTINATION CHARGE 1195.00 1195.00

TOTAL 34945.00 31394.65 PAY 310 31394.65

SVM INVOICE AMOUNT EXCLUDES HOLDBACK, GM MARKETING ADJUSTMENT AND OTHER DEALER FINANCE PROGRAMS.

THIS IS A RESTRICTIVE DIRECT SALE AND IS SUBJECT TO THE TERMS OF THE SPECIAL VEHICLE MANUFACTURERS PROGRAM.

ROYAL TRUCK BODY - PARAMOUNT

REMIT TO ALLY NO. 061
 VIN 1GB0CUEG7HZ217951
 \$ 31394.65 INV 1AD33863266
 DUE 01/30/17 DEALER 59-899

MEMO INVOICE: FINAL VIN # AND PRICE LEVEL
 SUBJECT TO CHANGE

DOES NOT INCLUDE HOLD BACK OR ADVERTISING

I have reviewed this vehicle factory invoice and acknowledge this is the vehicle I am requesting from Royal Truck Bodies bailment inventory.

Authorized by: _____ Date: _____ Dealer Code: _____



Prepared By:
administrator
crest chevrolet
909w 21 st
san bernardino, CA 92405
Phone: (909) 883-8833
Fax: (909) 882-8623
Email: danzank@crestchevy.com

2017 Fleet/Non-Retail Chevrolet Silverado 2500HD 2WD Reg Cab 133.6" W

STANDARD EQUIPMENT

STANDARD EQUIPMENT - 2017 Fleet/Non-Retail CC25903 2WD Reg Cab 133.6" Work Truck

ENTERTAINMENT

- Audio system, 4.2" Diagonal Color Display, AM/FM stereo with USB port and auxiliary jack (Upgradeable to (IOB) 7" diagonal color display radio with Chevrolet MyLink.) (Not available with (AZ3) 40/20/40 split-bench seat. Upgradeable to (IOB) 7" diagonal color display radio with Chevrolet MyLink.)
- XM Satellite Radio, delete
- Audio system feature, 4-speaker system on Regular Cab models

EXTERIOR

- Wheels, 17" (43.2 cm) steel includes 17" x 7.5" (43.2 cm x 19.1 cm) steel spare wheel. Spare not included with (ZW9) pickup box delete unless a spare tire is ordered
- Tires, LT245/75R17E all-season, blackwall
- Tire carrier lock keyed cylinder lock that utilizes same key as ignition and door (Not included when (ZW9) pickup box delete or (9J4) rear bumper delete is ordered.)
- Bumper, front chrome
- CornerStep, rear bumper (Requires (E63) pickup box.)
- Bumper, rear chrome with bumper CornerSteps (Requires (E63) pickup box.)
- Grille surround, chrome
- Headlamps, halogen projector-beam
- Lamps, cargo area, cab mounted with switch on center switch bank
- Mirrors, outside manual, Black
- Glass, solar absorbing, tinted
- Door handles, Black
- Tailgate and bed rail protection caps, top
- Tailgate, locking, utilizes same key as ignition and door (Not available with (AQQ) Remote Keyless Entry.)

Report content is based on current data version referenced. Any performance-related calculations are offered solely as guidelines. Actual unit performance will depend on your operating conditions.

GM AutoBook, Data Version: 476.0, Data updated 1/31/2017
© Copyright 1986-2012 Chrome Data Solutions, LP. All rights reserved.

Customer File:

Prepared By:
administrator
crest chevrolet
909w 21 st
san bernardino, CA 92405
Phone: (909) 883-8833
Fax: (909) 882-8623
Email: danzank@crestchevy.com

2017 Fleet/Non-Retail Chevrolet Silverado 2500HD 2WD Reg Cab 133.6" W

STANDARD EQUIPMENT

STANDARD EQUIPMENT - 2017 Fleet/Non-Retail CC25903 2WD Reg Cab 133.6" Work Truck

INTERIOR

- Seats, front 40/20/40 split-bench, 3-passenger, driver and front passenger recline with outboard head restraints and center fold-down armrest with storage. Vinyl has fixed lumbar and cloth has manually adjustable driver lumbar. (Upgradeable to (AZ3) front 40/20/40 split-bench seat.)
- Seat trim, Vinyl
- Floor covering, Graphite-colored rubberized-vinyl
- Steering column, manual Tilt-Wheel
- Steering wheel
- Instrumentation, 6-gauge cluster featuring speedometer, fuel level, engine temperature, tachometer, voltage and oil pressure
- Driver Information Center, 3.5-inch diagonal monochromatic display provides warning messages and basic vehicle information
- Door locks, power
- Cruise control, steering wheel-mounted
- Air conditioning, single-zone
- Assist handle, front passenger and driver on A-pillars

Report content is based on current data version referenced. Any performance-related calculations are offered solely as guidelines. Actual unit performance will depend on your operating conditions.

GM AutoBook, Data Version: 476.0, Data updated 1/31/2017
© Copyright 1986-2012 Chrome Data Solutions, LP. All rights reserved.

Customer File:

Prepared By:
administrator
crest chevrolet
909w 21 st
san bernardino, CA 92405
Phone: (909) 883-8833
Fax: (909) 882-8623
Email: danzank@crestchevy.com

2017 Fleet/Non-Retail Chevrolet Silverado 2500HD 2WD Reg Cab 133.6" W

STANDARD EQUIPMENT

STANDARD EQUIPMENT - 2017 Fleet/Non-Retail CC25903 2WD Reg Cab 133.6" Work Truck

MECHANICAL

- Engine, Vortec 6.0L Variable Valve Timing V8 SFI, E85-compatible, FlexFuel capable of running on unleaded or up to 85% ethanol (360 hp [268.4 kW] @ 5400 rpm, 380 lb-ft of torque [515.0 N-m] @ 4200 rpm) (Does not include E85 capability with (ZW9) pickup box delete.)
- Transmission, 6-speed automatic, heavy-duty, electronically controlled with overdrive and tow/haul mode. Includes Cruise Grade Braking and Powertrain Grade Braking (Requires (L96) Vortec 6.0L V8 SFI engine.)
- Rear axle, 4.10 ratio (Requires (L96) Vortec 6.0L V8 SFI engine.)
- Suspension Package, Standard includes 51mm twin tube shock absorbers and 33mm front stabilizer bar
- Pickup box
- GVWR, 9300 lbs. (4218 kg) (Requires Regular Cab model, (L96) Vortec 6.0L V8 SFI engine and 2WD.)
- Air cleaner, high-capacity
- Differential, heavy-duty locking rear
- Rear wheel drive
- Cooling, external engine oil cooler
- Cooling, auxiliary external transmission oil cooler
- Battery, heavy-duty 720 cold-cranking amps/80 Amp-hr, maintenance-free with rundown protection and retained accessory power
- Alternator, 150 amps
- Frame, fully-boxed, hydroformed front section
- Recovery hooks, front, frame-mounted, black
- Steering, Recirculating Ball with smart flow power steering system
- Brakes, 4-wheel antilock, 4-wheel disc with DuraLife brake rotors
- Capless Fuel Fill (Gas engine only. Not available with (ZW9) pickup box delete.)
- Exhaust, aluminized stainless-steel muffler and tailpipe

Report content is based on current data version referenced. Any performance-related calculations are offered solely as guidelines. Actual unit performance will depend on your operating conditions.

GM AutoBook, Data Version: 476.0, Data updated 1/31/2017
© Copyright 1986-2012 Chrome Data Solutions, LP. All rights reserved.

Customer File:

Prepared By:
administrator
crest chevrolet
909w 21 st
san bernardino, CA 92405
Phone: (909) 883-8833
Fax: (909) 882-8623
Email: danzank@crestchevy.com

2017 Fleet/Non-Retail Chevrolet Silverado 2500HD 2WD Reg Cab 133.6" W

STANDARD EQUIPMENT

STANDARD EQUIPMENT - 2017 Fleet/Non-Retail CC25903 2WD Reg Cab 133.6" Work Truck

SAFETY

- StabiliTrak, stability control system with Proactive Roll Avoidance and traction control includes electronic trailer sway control and hill start assist
- Daytime Running Lamps with automatic exterior lamp control
- Air bags Double and Regular Cab: Frontal Airbags- Driver single stage and Front Passenger dual-stage; Thorax side-impact, seat mounted, both driver and front passenger; Head-curtain front and rear outboard seating positions; Passenger Sensing System - Infant only suppression for passenger and passenger seat belt reminder status displayed on overhead console (With (ZW9) pickup box delete on Double and Regular Cab you will get single-stage frontal and thorax side-impact, driver and front passenger, and head curtain side-impact, front and rear outboard seating positions. Always use safety belts and child restraints. Children are safer when properly secured in a rear seat in the appropriate child restraint. See the Owner's Manual for more information.)
- OnStar, delete also deletes driver information center compass
- Teen Driver mode a configurable feature that lets you activate customizable vehicle settings associated with a key fob, to encourage safe driving behavior. It can limit certain vehicle features, and it prevents certain safety systems from being turned off. An in-vehicle report gives you information on your teen's driving habits and helps you to continue to coach your new driver
- Tire Pressure Monitoring System (does not apply to spare tire)

Report content is based on current data version referenced. Any performance-related calculations are offered solely as guidelines. Actual unit performance will depend on your operating conditions.

GM AutoBook, Data Version: 476.0, Data updated 1/31/2017
© Copyright 1986-2012 Chrome Data Solutions, LP. All rights reserved.

Customer File:

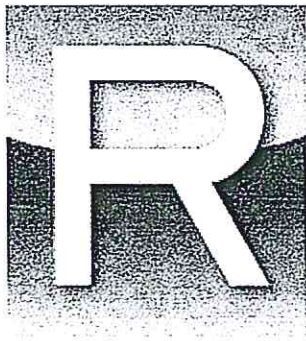

ROYAL TRUCK BODY

14001 GARFIELD AVENUE
PARAMOUNT, CA 90723
PHONE: 562-633-9951
FAX: 562-633-2277

QUOTATION		0254848	
DATE ENTERED	TRUCK ORIGIN	DATE REQUESTED	
2/16/2017	POOL-PAR		
WRITTEN BY	SALESMAN	TERR	DATE PROMISED
YC	ML	ML	
END USER (IF DIFFERENT THAN SOLD TO)			

CUSTOMER NO: CREST

S CREST CHEVROLET
O 909 W. 21ST STREET
L SAN BERNARDINO, CA 92405

S CREST CHEVROLET
H 909 W. 21ST STREET
I SAN BERNARDINO, CA 92405
P

CUST ORDER NO	TERMS	SHIP VIA	CUSTOMER NAME	CUSTOMER PHONE NO					
	02	ROYAL	DAN Z						
MAKE TRUCK	YEAR	MODEL	COLOR	CA DIM	DUAL	SINGLE	DOOLEY	AUX TANK	ENGINEERED BY
Chevy	17	CC25903	WHITE	56		X		N	
STOCK NO.	V.I.N. NO.	BED WIDTH	COMPT. DEPTH	OVERALL WIDTH					
		49	15	79					

QTY	PART NO./DESCRIPTION	UNIT PRICE	EXT PRICE
	<div style="display: flex; justify-content: space-around;"> CURB SIDE <input type="checkbox"/> STREET SIDE <input type="checkbox"/> </div> <p>2017/POOL UNIT/CHEVY/CC25903/SRW/REG. CAB CHASSIS/56"CA</p>		
1	<p>40-VO-98 40"H ROYAL BODY w/OPEN TOP LID</p> <p>5 POINT FORTRESS LOCKING SYSTEM, CODEABLE LOCKS, WEIGHT CERTIFICATE, PAINTED WHITE AND INSTALLED.</p> <p>ALUMINUM LID COVERS, APPEARANCE PACKAGE, 8" RECESSED ROYAL BUMPER, LEGAL LIGHT PACKAGE.</p> <p>REMOVABLE STORAGE BINS IN OPEN TOP COMPARTMENTS BOTH SIDES, 4 TIE DOWNS IN BED AREA.</p>	5,819.0000	5,819.00
1	<p>H-2 CLASS 5 RECEIVER HITCH (2-1/2" RECEIVER TUBE) AND HITCH INSERT, 16,000 LBS. GTW</p>	550.0000	550.00
1	<p>H-4 7 BLADE/ 4 PIN TRAILER CONNECTOR</p>	175.0000	175.00
1	<p>IML-98</p>	1,026.0000	1,026.00

Continued

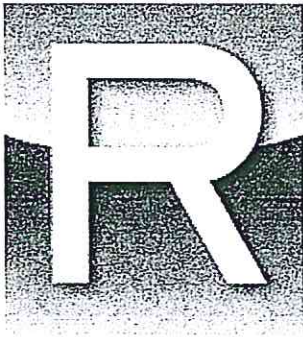

ROYAL TRUCK BODY

14001 GARFIELD AVENUE
PARAMOUNT, CA 90723
PHONE: 562-633-9951
FAX: 562-633-2277

QUOTATION			0254848	
DATE ENTERED	TRUCK ORIGIN	DATE REQUESTED		
2/16/2017	POOL-PAR			
WRITTEN BY	SALESMAN	TERR	DATE PROMISED	
YC	ML	ML		
END USER (IF DIFFERENT THAN SOLD TO)				

S CREST CHEVROLET O 909 W. 21ST STREET L SAN BERNARDINO, CA 92405		CUSTOMER NO: CREST		S CREST CHEVROLET H 909 W. 21ST STREET I SAN BERNARDINO, CA 92405 P	
---	--	--------------------	--	--	--

CUST ORDER NO	TERMS	SHIP VIA	CUSTOMER NAME	CUSTOMER PHONE NO					
	02	ROYAL	DAN Z						
MAKE TRUCK	YEAR	MODEL	COLOR	CA DIM	DUAL	SINGLE	DOOLEY	AUX TANK	ENGINEERED BY
Chevy	17	CC25903	WHITE	56		X		N	
STOCK NO.	V.I.N. NO.	BED WIDTH		COMPT. DEPTH		OVERALL WIDTH			
		49		15		79			

QTY	PART NO./DESCRIPTION	UNIT PRICE	EXT PRICE
	<div style="display: flex; justify-content: space-around;"> CURB SIDE <input type="checkbox"/> VO STREET SIDE <input type="checkbox"/> VO </div> <p>INTERNAL MASTER LOCK 98" SYSTEM FEATURING A TWIST HANDLE THAT CAN BE LOCKED WITH CUSTOMER SUPPLIED PADLOCK ENABLING ADDITIONAL SECURITY.</p>		
1	M-1 VISE BRACKET, 12" X 7", STAINLESS STEEL MOUNT REAR S/S	273.0000	273.00
1	/DD-S LESS: DEALER DISCOUNT - SUB	-1,569.0000	1,569.00-

THANK YOU FOR CHOOSING ROYAL TRUCK BODY!!!

DEPOSIT AMT _____ CHECK NO _____ DRIVER'S LIC. _____ EXP DATE _____
 RELEASED BY _____ DATE _____ KEY NO. _____
 RECEIVED BY _____ DATE _____

Freight:	0.00
Net Order:	6,274.00
Sales Tax:	0.00
GRAND TOTAL:	6,274.00

In Consideration of allowing you to remove your vehicle from our premises prior to full payment of the underlying work order, the undersigned, Alasheh, Dora, hereby agrees that if any litigation arises out of this transaction the prevailing party shall be entitled to reimbursement for court costs and attorney's fees.

SALES ORDER # 0254848

Prepared By:
administrator
crest chevrolet
909w 21 st
san bernardino, CA 92405
Phone: (909) 883-8833
Fax: (909) 882-8623
Email: danzank@crestchevy.com

2017 Fleet/Non-Retail Chevrolet Silverado 2500HD 2WD Reg Cab 133.6" W

WARRANTY INFORMATION

WARRANTY INFORMATION - 2017 Fleet/Non-Retail CC25903 2WD Reg Cab 133.6" Work Truck

WARRANTY

Basic:

3 Years/36,000 Miles

Drivetrain:

5 Years/60,000 Miles

HD Duramax Diesel: 5 Years/100,000 Miles; Qualified Fleet Purchases: 5 Years/100,000

Miles

Corrosion:

3 Years/36,000 Miles

Rust-Through

6 Years/100,000 Miles

Roadside Assistance:

5 Years/60,000 Miles

HD Duramax Diesel: 5 Years/100,000 Miles; Qualified Fleet Purchases: 5 Years/100,000

Miles

Maintenance:

2 Years/24,000 Miles

2 visits

Report content is based on current data version referenced. Any performance-related calculations are offered solely as guidelines. Actual unit performance will depend on your operating conditions.

GM AutoBook, Data Version: 476.0, Data updated 1/31/2017
© Copyright 1986-2012 Chrome Data Solutions, LP. All rights reserved.
Customer File:

Rubidoux Community Services District

Board of Directors
Christopher Barajas
Armando Muniz
Bernard Murphy
F. Forest Trowbridge
Ruth Anderson Wilson

Secretary-Manager
David D. Lopez

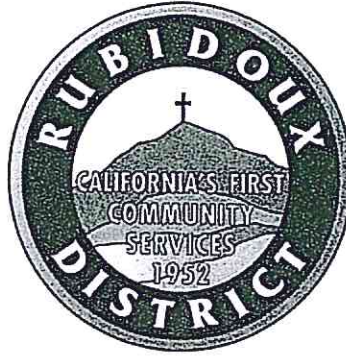

Raewy
RECEIVED
FEB 22 2017
BY: _____ 11:45 AM

Water Resource Management Refuse Collection Street Lights Fire / Emergency Services Weed Abatement

February 8, 2017

SUBJECT: Request for Quotation - Two (2) New 2016 or 2017, ¾ Ton, 9,000 GVW or equivalent, 8 Ft Utility Bed Trucks, Two-Wheel Drive, V8, Automatic.

Dear Sir or Madame:

The Rubidoux Community Services District (District) is requesting a proposal for the purchase of two (2) new (2016 or 2017 Model Year) Two-Wheel Drive, V8, Automatic, ¾ Ton Utility Bed Trucks. The District, a public agency located in the County of Riverside, California, is eligible for all Standard Governmental Service Fleet Pricing and Warranties.

NOTE: IT IS THE INTENT OF THE DISTRICT TO TAKE DELIVERY "OFF THE LOT" RATHER THAN ORDER THE VEHICLE.

Winning bidder must be able to deliver the vehicle within 2 weeks or earlier of the award date of March 3, 2017. Delivery date of March 17, 2017 or earlier.

Dealers should submit Bids to Rubidoux Community Services District, based on the attached specifications, no later than 4:00 PM on Wednesday, February 22, 2017.

Should you have any questions, please do not hesitate to contact me directly at the District office.

Sincerely,

Brian Jennings
Manager Budgeting and Accounting

Attachments:
Minimum Specification Sheet(s) Truck #1 and Truck #2
Quote Sheet(s) Truck #1 and Truck #2

RUBIDOUX COMMUNITY SERVICES DISTRICT

3590 Rubidoux Blvd. P.O. Box 3098

Jurupa Valley, CA 92519

(951) 684-7580 - Fax (951) 369-4061

Utility Bed Truck # 1

Vehicle Specifications

NOTE: Vendor must indicate either "Yes" or "No" in the columns labeled "Meets Spec".

<u>Meets Spec</u>	<u>Comments</u>
-------------------	-----------------

Model:

8 FT Utility Bed Truck – 2 Door Regular Cab 2WD, 3/4-Ton GVW 9,000 or Similar	yes	
--	-----	--

Color:

Exterior - White	yes	
Interior - Any	yes	

Cab:

Seats – Vinyl/Cloth	yes	
Flooring - Vinyl	yes	

Engine:

V8 Gasoline, 6.2 L, 430 Foot lbs Torque or greater EFI V8	yes	
--	-----	--

Transmission:

5 or 6-Speed Automatic With Overdrive HD	yes	
--	-----	--

Electrical:

Cold Cranking - 650 Amps or better Reserve Capacity - 115 Minutes or better	yes	
--	-----	--

Cooling System:

Heavy Duty Radiator	yes	
---------------------	-----	--

Frame:

All-Welded Ladder Type	yes	
------------------------	-----	--

Suspension:

Front:

Heavy Duty - Independent Coil Springs	yes	
---------------------------------------	-----	--

Rear:

Heavy Duty - Semi-Elliptic, Two-Stage, Multi-Leaf	yes	
---	-----	--

Axles:

Limited Slip, <u>Single Rear Wheels</u>	NO	Regular axle 3.73 ratio
---	----	----------------------------

Tires:

LT245/75R-17/D All Season Black wall (or better)	yes	
Full Size Spare Tire W/ Steel Wheel		
17" Silver Painted Steel Wheel W/ Argent Center Cap		
Under-Body Mounted Locking Winch-Type Spare Tire Carrier		

Brakes:

Heavy Duty - Hydraulic Power 4 Wheel Disc Brakes	yes	
---	-----	--

Fuel Tank:

Capacity - 30 Gallons or greater	yes	
----------------------------------	-----	--

Battery:

HD 600 CCA Battery or better	yes	
------------------------------	-----	--

Radio

AM/FM	yes	
-------	-----	--

Air Conditioning

Factory Air Conditioner	yes	
-------------------------	-----	--

Safety

4-Wheel Anti-Lock Brake System	yes	
Driver & Front Passenger Airbags With Passenger Side Deactivation Switch		
Manual Lap/Shoulder Safety Belts, Outboard Seat Position		
Manual Lap Safety Belts, Center Seat Position		
Head Restraints At Outboard Seating Positions		
Daytime Running Lamps		

	OR Equal	Meets Spec	Comments
Utility Body	See Attached (Last Pages) - <u>Scelzi Body/Harbor Trade Master or Equal</u>	yes	Harbor
Locks	Internal Master Locks, Push Pull	yes	
Paint	Paint Factory White	yes	
Bumper	Recessed Bumper (Weight Certificate)	yes	
Lights	Legal Light Package With 7 wires Harness/ Wiring	yes	
Trailer Hitch	Heavy Duty Tow Package <i>(Std tow package - only package available w/o. 2 motor</i>	yes	13,000 lb Capacity
Lid Covers	Aluminum or Stainless Open-Top Model Appearance Package	yes	
Vise Brackets	Mounted On Left (Driver Side)	yes	

Rubidoux Community Services District is a public agency located in the County of Riverside, California, and is eligible for all Standard Governmental Service Fleet Pricing and Warranties.

Additional equipment and/or upgraded modification should be listed as a separate item to allow an accurate and effective evaluation of submitted bids. All modifications to the minimum specifications, as stated above, shall be clearly identified. The quote should have 150,000 mile, 5 year, 6,000 engine hour extended warranties that should also be included in the submitted proposal and options for the vehicle.

The vehicle quoted price shall include all applicable state and local taxes, licenses, dealer transportation and preparation fees. Vehicles shall be "Highway Ready" with registration plates being filed "Exempt" by the dealer(s) with the Department of Motor Vehicles.

The above vehicles shall be fully fueled and lubricated.

RUBIDOUX COMMUNITY SERVICES DISTRICT

QUOTATION REQUEST

The Rubidoux Community Services District is requesting quotations to furnish and deliver equipment as described per attached District standard vehicle specification. Note: The total price quoted shall include all applicable taxes and delivery cost. "E" license are required.

<u>Term</u>	(1) Model Year 2016 or 2017, 3/4 Ton 9,000 GVW or equivalent 8 FT Utility Bed Truck (Truck #1)	PRICE \$ <u>30,272⁸²</u>
<u>Warranty</u>	150,000 Miles/5 Year; 6,000 Engine Hour (Extended Warranty)	\$ <u>3,315⁰⁰</u> ^{EN}
<u>ESP</u>	Premium CARE	df TAX \$ <u>2,441⁰⁹</u> ^{EN}
<u>Trade In Item</u>	2009 Ford F150 PickUp VIN # 1FTMF1CW0AKB37077 Approximately 52,000 miles	\$(<u>7,000⁰⁰</u>) TOTAL \$ <u>29,028⁹¹</u>

The intended target vehicle is a ¾ ton, 4x2 Truck, V8, automatic. It is preferred that the winning bidder be able to deliver the vehicle within 2 weeks or earlier of the award date. Otherwise bidder need provide best estimate of delivery date in bid quote.

The equipment quoted shall be furnished in compliance with the State of California Air Resource Board standards and as comparable to the attached specification sheets **for delivery by March 17, 2017 or earlier.**

Proposals should arrive at the District office no later than 4:00 pm, Wednesday, February 22, 2017. It is anticipated that the District shall award the contract at the regularly scheduled meeting of the Board of Directors, March 2, 2017. The District will issue to the awarded dealer a Purchase Order for the vehicle the day following Board approval. Upon vehicle delivery

TRUCK # 1

and acceptance by the District, payment shall be made in full to the selected dealer within thirty (30) calendar days.

The District reserves the right to reject any and all bids received.

Written proposals should be submitted to: Attn: Brian Jennings
Rubidoux Community Services District,
3590 Rubidoux Blvd.
Jurupa Valley, California 92509

Faxed proposals may be transmitted to RCSD Attn: Brian Jennings at (951) 369-4061.

Said envelope shall also contain the following in the lower left-hand corner thereof:

Proposal of _____ (Name of Bidder) _____

For: One (1) Model Year 2016 or 2017, 3/4 Ton, 8 Ft Utility Truck Bid (Truck #1)

Signed: Campbell Company: Raceway Ford

Title: Fleet Manager Address: 5900 Sycamore Canyon

Date: 2/22/17 City: Riverside

Estimated Delivery Date: 3/17/17

RUBIDOUX COMMUNITY SERVICES DISTRICT

3590 Rubidoux Blvd. P.O. Box 3098

Jurupa Valley, CA 92519

(951) 684-7580 - Fax (951) 369-4061

Utility Bed Truck # 2

Vehicle Specifications

NOTE: Vendor must indicate either "Yes" or "No" in the columns labeled "Meets Spec".

	<u>Meets Spec</u>	<u>Comments</u>
Model:		
8 FT Utility Bed Truck – 2 Door Regular Cab 2WD, 3/4-Ton GVW 9,000 or Similar	yes	
Color:		
Exterior - White	yes	
Interior - Any	yes	
Cab:		
Seats – Vinyl/Cloth	yes	
Flooring - Vinyl	yes	
Engine:		
V8 Gasoline, 6.2 L, 430 Foot lbs Torque or greater EFI V8	yes	
Transmission:		
5 or 6-Speed Automatic With Overdrive HD	yes	
Electrical:		
Cold Cranking - 650 Amps or better Reserve Capacity - 115 Minutes or better	yes	
Cooling System:		
Heavy Duty Radiator	yes	
Frame:		
All-Welded Ladder Type	yes	
Suspension:		
Front:		
Heavy Duty - Independent Coil Springs	yes	
Rear:		
Heavy Duty - Semi-Elliptic, Two-Stage, Multi-Leaf	yes	
Axles:		
Limited Slip, <u>Single Rear Wheels</u>	NO	Regular axle 3.73 ratio

Tires:

LT245/75R-17/D All Season Black wall (or better)	yes	
Full Size Spare Tire W/ Steel Wheel		
17" Silver Painted Steel Wheel W/ Argent Center Cap		
Under-Body Mounted Locking Winch-Type Spare Tire Carrier		

Brakes:

Heavy Duty - Hydraulic Power 4 Wheel Disc Brakes	yes	
---	-----	--

Fuel Tank:

Capacity - 30 Gallons or greater	yes	
----------------------------------	-----	--

Battery:

HD 600 CCA Battery or better	yes	
------------------------------	-----	--

Radio

AM/FM	yes	
-------	-----	--

Air Conditioning

Factory Air Conditioner	yes	
-------------------------	-----	--

Safety

4-Wheel Anti-Lock Brake System	yes	
Driver & Front Passenger Airbags With Passenger Side Deactivation Switch		
Manual Lap/Shoulder Safety Belts, Outboard Seat Position		
Manual Lap Safety Belts, Center Seat Position		
Head Restraints At Outboard Seating Positions		
Daytime Running Lamps		

	OR Equal	Meets Spec	Comments
Utility Body	See Attached (Last Pages) – <u>Scelzi Body/Harbor Trade Master or Equal</u>	yes	Harbor
Locks	Internal Master Locks, Push Pull	yes	
Paint	Paint Factory White	yes	
Bumper	Recessed Bumper (Weight Certificate)	yes	
Lights	Legal Light Package With 7 wires Harness/ Wiring	yes	
Trailer Hitch	Heavy Duty Tow Package <i>only std tow package avail. with 6.2 motor</i>	yes	13,000 capacity
Lid Covers	Aluminum or Stainless Open-Top Model Appearance Package	yes	
Vise Brackets	Mounted On Left (Driver Side)	yes	

Rubidoux Community Services District is a public agency located in the County of Riverside, California, and is eligible for all Standard Governmental Service Fleet Pricing and Warranties.

Additional equipment and/or upgraded modification should be listed as a separate item to allow an accurate and effective evaluation of submitted bids. All modifications to the minimum specifications, as stated above, shall be clearly identified. The quote should have 150,000 mile, 5 year, 6,000 engine hour extended warranties that should also be included in the submitted proposal and options for the vehicle.

The vehicle quoted price shall include all applicable state and local taxes, licenses, dealer transportation and preparation fees. Vehicles shall be "Highway Ready" with registration plates being filed "Exempt" by the dealer(s) with the Department of Motor Vehicles.

The above vehicles shall be fully fueled and lubricated.

RUBIDOUX COMMUNITY SERVICES DISTRICT

QUOTATION REQUEST

The Rubidoux Community Services District is requesting quotations to furnish and deliver equipment as described per attached District standard vehicle specification. Note: The total price quoted shall include all applicable taxes and delivery cost. "E" license are required.

<u>Term</u>	(1) Model Year 2016 or 2017, 3/4 Ton 9,000 GVW or similar 8 FT Utility Bed Truck (Truck #2)	PRICE \$ <u>30,272⁸²</u>
<u>Warranty</u>	150,000 Miles/5 Year; 6,000 Engine Hour (Extended Warranty) ESP Premium Care	\$ <u>3315⁰⁰</u> TAX \$ <u>2,441^{09 42}</u>
<u>Trade In Item</u>	2011 Ford F250 Utility Bed VIN # 1FDBF21A63BEA85357 Approximately 72,000 miles	\$(<u>10,000⁰⁰</u>) TOTAL \$ <u>24,028⁹¹</u>

The intended target vehicle is a ¾ Ton, 4x2 Truck, V8, automatic. It is preferred that the winning bidder be able to deliver the vehicle within 2 weeks or earlier of the award date. Otherwise bidder need provide best estimate of delivery date in bid quote.

The equipment quoted shall be furnished in compliance with the State of California Air Resource Board standards and as comparable to the attached specification sheets **for delivery by March 17, 2017 or earlier.**

Proposals should arrive at the District office no later than 4:00 pm, Wednesday, February 22, 2017. It is anticipated that the District shall award the contract at the regularly scheduled meeting of the Board of Directors, March 2, 2017. The District will issue to the awarded dealer a Purchase Order for the vehicle the day following Board approval. Upon vehicle delivery

TRUCK # 2

and acceptance by the District, payment shall be made in full to the selected dealer within thirty (30) calendar days.

The District reserves the right to reject any and all bids received.

Written proposals should be submitted to: Attn: Brian Jennings
Rubidoux Community Services District,
3590 Rubidoux Blvd.
Jurupa Valley, California 92509

Faxed proposals may be transmitted to RCSD Attn: Brian Jennings at (951) 369-4061.

Said envelope shall also contain the following in the lower left-hand corner thereof:

Proposal of _____ (Name of Bidder) _____

For: One (1) Model Year 2016 or 2017, 3/4 Ton, 8 Ft Utility Truck Bid (Truck #2)

Signed: Carly Ruzo Company: Raccoony Ford

Title: Fleet Manager Address: 5900 Sycamore Canyon

Date: 2/22/17 City: Riverside

Estimated Delivery Date: 3/17/17

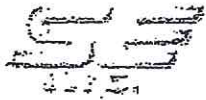

8 ft. Service Body Datasheet

Standard Accessories and Features

- Chrome L-bar handle latches with polished stainless steel pockets and Galvaneal steel locking rods.
- Three point latching system on all compartment doors.
- Full-length, 5/16" stainless steel door shafts and hinge blocks with nylon inserts. On all compartment.
- All hinge blocks fastened with stainless steel mono bolts.
- All compartment doors equipped with barrel locks.
- Gas shocks on open top compartments.
- Seat-beam type tail and clearance lights.
- Gas shocks on all compartment doors.
- Scelzi exclusive door seal.
- All bodies equipped with a six inch step bumper.
- Bodies fastened to frame at six mounting points.
- All seams are caulked with 3M ultra pro seam sealer.
- Complete under sealing of bed and wheel wells. Multiple coats of primer and urethane paint to maintain durability.
- Wiring built as harnesses and run thru loop clamps to prevent chafing and to secure mounting.
- Stainless steel tubing around wheel well openings.
- Self-leveling tailgate with stainless steel cap and guard rail. Diamond plate inner lining.
- *Vise Bracket - Mounted Left (Owner's side)*

Material

- Exterior structural body panels.
- Door post: 14 Gauge Galvaneal steel.
- End caps: 14 Gauge Galvaneal steel.
- Back wrapper: 14 Gauge Galvaneal steel.
- Closed tops and open top lids: 16 Gauge Galvaneal steel.
- Flooring: 12 Gauge diamond plate.
- Bulkhead: 14 Gauge Galvaneal steel.
- Interior structural body panels.
- Door skin: 18 Gauge Galvaneal steel.
- Inner door skin: 20 Gauge Galvaneal steel.

Unacceptable Practices and Components

- Body mounting using only four points.
- Clip-in adjustable shelving.
- Single panel doors.
- Wiring running through interior of compartments.
- Shelving made from material other than 16 Gauge Galvaneal steel.
- Piano hinges on compartment doors.

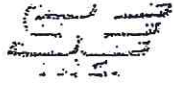

8 ft. Service Body Schematic

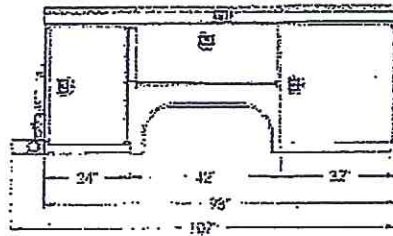
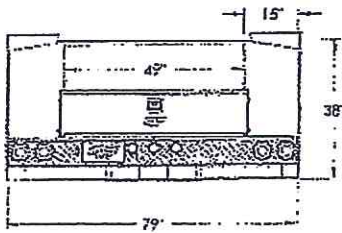
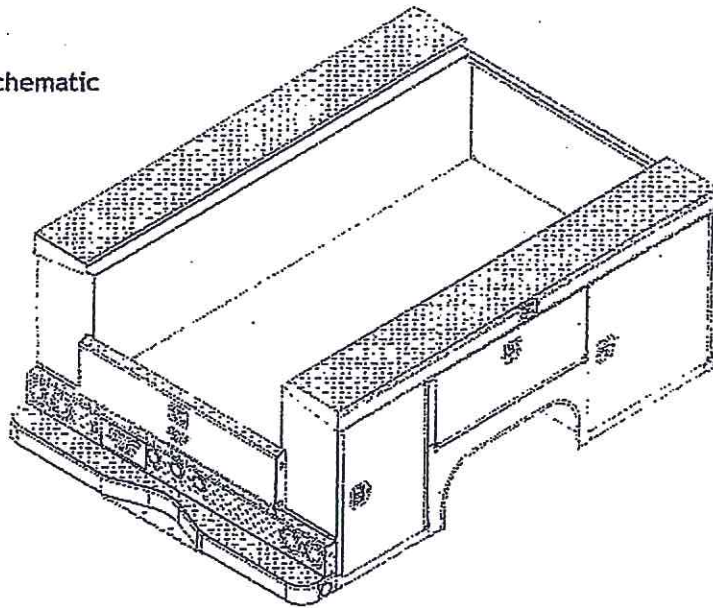

8-ft. TradeMaster

For 56" Cab-to-Axle Trucks with 8600 GVWR Minimum

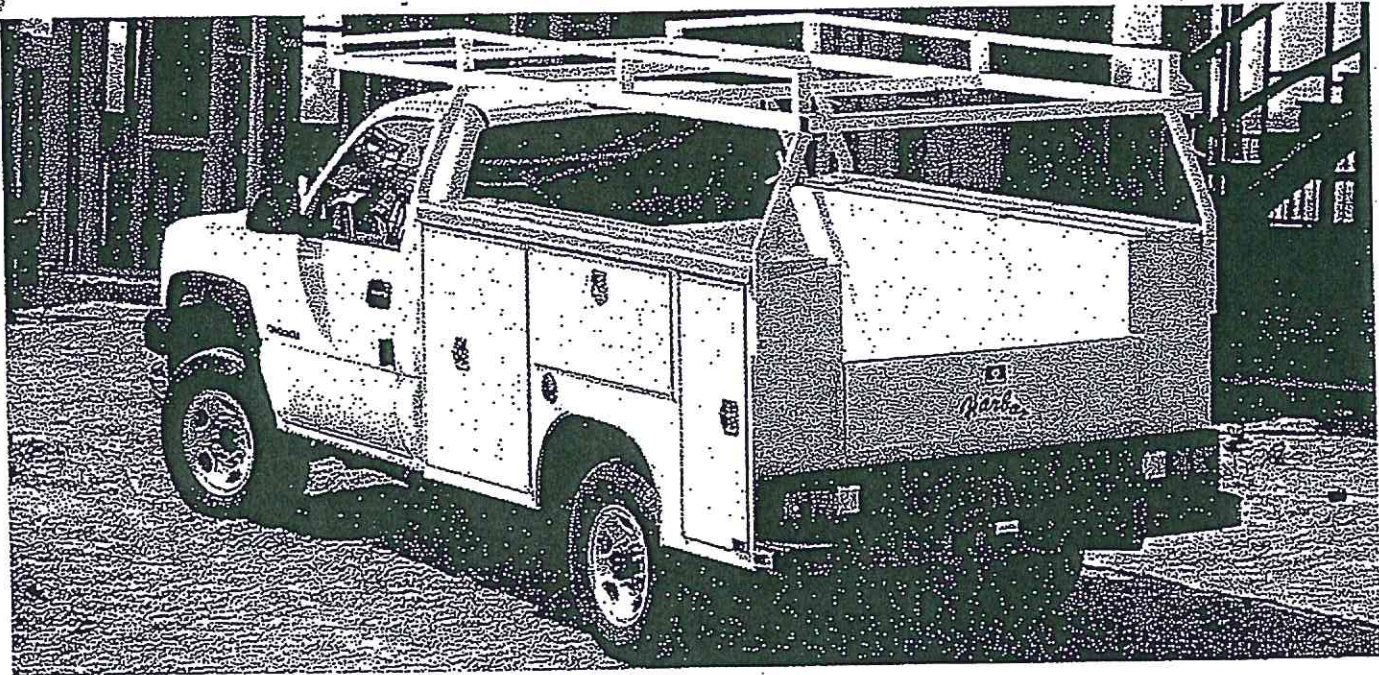

8-FT TRADEMASTER DIMENSIONS

STANDARD OPEN-TOP
VERTICAL SERIES

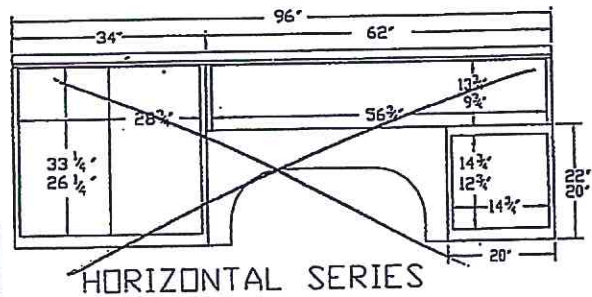
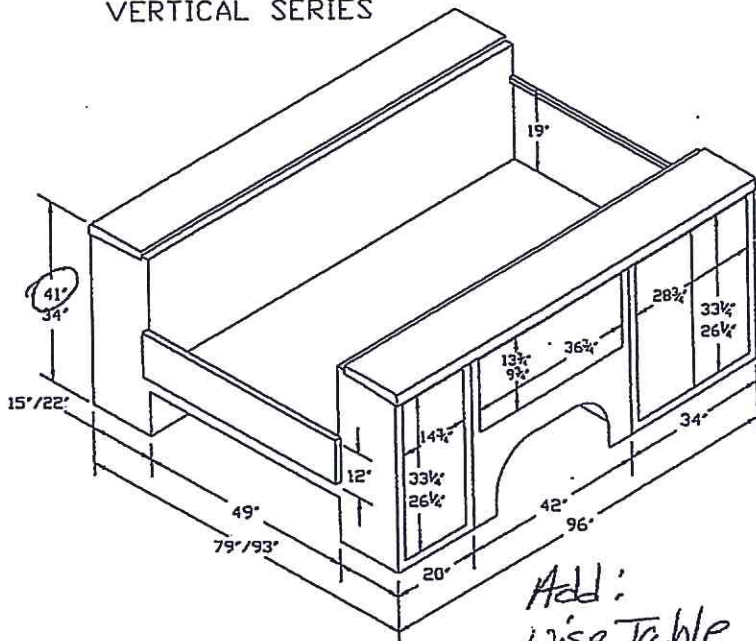

HORIZONTAL SERIES

CLOSED-TOP
MODEL

OPEN-TOP
MODEL

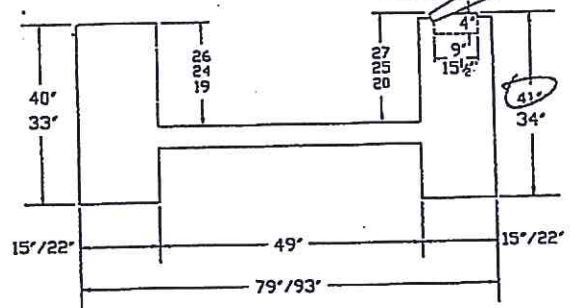

NOTE:

- DOOR COMPARTMENT DIMENSIONS ARE THE CLEAR DOOR OPENING.
- TOP VERTICAL DIMENSIONS ARE STANDARD HEIGHT BODIES
BOTTOM DIMENSIONS ARE LOW PROFILE BODIES

Raceway Ford
5900 Sycamore Canyon Blvd
Riverside, CA 92507
(951) 784-1000



Date: 02/22/2017 Salesperson: Ringo, Gary
Deal Number: 69791

FEB 22 17 10:09:06

Find Number 69791 Salesperson Ringo, Gary Date 02/22/2017
Buyer Rubidoux Community Services District Co Buyer _____
Address 3590 Rubidoux Blvd. City Rubidoux State CA Zip 92509
Home (951) 684-7580 Work _____ Cell _____ Email _____
New/Used New Stock# 17F1041 Year 2017 Make Ford Model F250 4X2 STYLESIDE P
Mileage 0 Color Oxford White VIN# 1FTBF2A67HEB48019

TRADE INFORMATION

Year: 0 Make: _____ Model: _____
VIN#: _____
Mileage: _____ Color: _____

PRICE: \$ 34450.00

Additional Accessories:

Truck #1

Payment Disclosure for Purchase

Interest Rate: 0.00
Payment Frequency: Cash Deal
Number of Payments: 0
Days to 1st Pmnt: 0
First Payment Date: 02/22/2017
Payment/Amt Due: 0 29,028.91

Disclosure Summary for Purchase

Price	34,450.00
Less Discount	-10,066.00
Vehicle Price	24,384.00
Trade Value	7,000.00
Trade Difference	17,384.00
Accessories	5,888.82
Sub Total	23,272.82
Tax	2,352.34
Documentation Fee	80.00
Service Contract	3,315.00
	0.00
Trade Payoff	0.00
TriVIN Fee	0.00
License Fees	0.00
Title/Reg Fees	0.00
Tire Fee	8.75
Smog Fee	0.00
Total	29,028.91
Less Down Payment	0.00
Amount Due	29,028.91

Salesperson cannot accept this offer or obligate seller in any manner whatsoever. THIS OFFER IS NOT BINDING UNTIL ACCEPTED IN WRITING BY OFFICER OR SALES MANAGER OF DEALERSHIP



Disclaimer: This window sticker is only representative of the information contained on an actual window sticker, and may or may not match the actual window sticker on the vehicle itself. Please see your retailer for further information.

Vehicle Description

VIN 1FTBF2A67HE B48019

F-SERIES 2017 F250 4X2 SD R/C
SD 6.2L EFI V-8 ENGINE
 6 SPEED AUTOMATIC TRANS G

Exterior
 OXFORD WHITE
Interior
 MEDIUM EARTH GRAY VINYL 40/20/40 SEATS

Standard Equipment INCLUDED AT NO EXTRA CHARGE

EXTERIOR

- . DOOR HANDLES - BLACK
- . LOCKING REMOVABLE TAILGATE
- . PICKUP BOX, TIE DOWN HOOKS
- . SPARE TIRE AND WHEEL LOCK
- . TOW HOOKS

INTERIOR

- . DRIVER SEAT-MANUAL LUMBAR
- . PARTICULATE AIR FILTER
- . VINYL SUN VISORS

FUNCTIONAL

- BRAKING SYSTEM
- . JEWEL EFFECT HEADLAMPS
- . TWIN I-BEAM INDEPENDENT

SAFETY/SECURITY

- . AIRBAGS - SAFETY CANOPY
- . DRIVER/PASSENGER AIR BAGS
- . SOS POST CRASH ALERT SYS

WARRANTY

- . 5YR/60,000 POWERTRAIN

- . BOX RAIL/TAILGATE MOLDINGS
- . HEADLAMPS -WIPER ACTIVATED W/LIFT ASST-NA W/BOX DLT
- . -NA W/BOX DLT
- . -NA W/BOX DLT
- . TRAILER SWAY CONTROL
- . AIR COND, MANUAL FRONT
- . OUTSIDE TEMP DISPLAY
- . TILT/TELESCOPE STR COLUMN
- . 4-WHEEL ANTI-LOCK DISC
- . HILL START ASSIST
- . MYKEY
- FRT SUSPENSION W/STAB BAR
- . ADVANCETRAC WITH RSC
- . BELT-MINDER CHIME
- . SECURILOCK PASS ANTI THEFT
- . 3YR/36,000 BUMPER / BUMPER
- . 5YR/60,000 ROADSIDE ASSIST

Price Information
STANDARD VEHICLE PRICE

MSRP
\$32,535

Optional Equipment

- 2017 MODEL YEAR
- OXFORD WHITE
- MEDIUM EARTH GRAY VINYL PREFERRED EQUIPMENT PKG.600A
- .XL TRIM
- .TRAILER TOWING PACKAGE
- .AIR CONDITIONING -- CFC FREE
- .6.2L EFI V-8 ENGINE
- 6 SPEED AUTOMATIC TRANS G
- .LT245/75R17E BSW ALL SEASON 3.73 RATIO REGULAR AXLE
- JOB #1 ORDER
- XL DECOR PACKAGE
- 9950# GVWR PACKAGE
- 50 STATE EMISSIONS
- SPARE TIRE AND WHEEL JACK
- XL VALUE PACKAGE 720
- .CRUISE CONTROL
- .AM/FM STEREO CD/CLK

TOTAL VEHICLE & OPTIONS 33,255
 DESTINATION & DELIVERY 1,195

TOTAL MSRP \$34,450

Disclaimer: Option pricing will be blank for any item that is priced as 0 or "No Charge".



CITY MPG
0
HIGHWAY MPG
0

Estimated Annual Fuel Cost: \$

Vehicle Engine Information

Actual mileage will vary with options, driving conditions, driving habits and vehicle's condition. Results reported to EPA indicate that the majority of vehicles with these estimates will achieve between _ and _ mpg in the city and between _ and _ mpg on the highway. For Comparison Shopping all vehicles classified as have been issued mileage ratings from _ to _ mpg city and _ to _ mpg highway.



EXTENDED SERVICE PLAN

Ford Extended Service Plan is the ONLY service contract backed by Ford and honored by the Ford and Lincoln dealers. Ask your dealer for prices and additional details or see our website at www.Ford-ESP.com.



HARBOR TRUCK BODIES, INC.
 255 VOYAGER AVENUE
 BREA, CA 92821
 (714) 996-0411 • (800) 433-9452
 FAX (714) 996-0695

SCHED. SHIP DATE WEEK OF	PAGE NO.	ORDER NO.	CANCELLATION DATE	CUST. NO.
	1	75058	02/09/18	FLR03

SALES ORDER

S
O
L
D
T
O

RACEWAY FORD-GARY
 DEALER# 716154
 5900 SYCAMORE CYN. BLVD.
 RIVERSIDE, CA 92507

S
H
I
P
T
O

RACEWAY FORD
 DEALER# 716154
 5900 SYCAMORE CYN. BLVD.
 RIVERSIDE, CA 92507

ORDER DATE 02/09/17	PURCHASE ORDER NO.	SHIP VIA HARBOR	F.O.B. ORIGINATION	TERMS NET 30		
BUYER GARY	12/31/44	LOCATION WHSE1	SALESPERSON FORD - LA - SOUTH	TERRITORY SOUTHERN CALIF		
ITEM NO. BIN LOCATION NO.	DESCRIPTION	QUANTITY ORDERED	QUANTITY BACK ORD.	QUANTITY SHIPPED	UNIT PRICE	EXTENSION
FORD-056-R-SRW	FORD F250/F350-REGULAR CAB VIN: MODEL YEAR: 2017 GAS ENGINE DEALER CHASSIS	1				
HT098-1541A	TRADEMASTER 8'-VERT 2 SDS STAINLES TOP 98LX79W CPT-15DX41H-DT FL-49W CA56SRW	1			4702.06	4702.06
D30-HANDLE	MASTER LOCK-98" BODIES-HANDLE STYLE Incl Harbor Std Lock-Not Push-But or ADK	1			836.83	836.83
Y08AWHITE	PAINT FACTORY WHITE - 8-FT TRADEMASTER	1				
Z08/BRL79-08-LED	MOUNT 8-FT BODY W/BRL79-08 RECESS BUMPER LED SYS-STOP/TAIL/TURN/BACKUP/LIC	1			119.93	119.93
SUB TOTAL		Please sign below to confirm that you have authorized the purchase of all of the above items at the prices shown. This purchase is subject to all terms and conditions noted on the reverse side of the Customer Receipt Copy.			5658.82	
KIMBERLY/SALES		Authorized Signature	Date	Purchase Order No.	WORK ORDER NO. 75058	TOTAL ORDER VALUE 5658.82

*add Wise Table
 + 230⁰⁰
 5888.82*

ORIGINAL

Lending/Retail/Auction Breakdown

Kelley Blue Book

2/17/2017-2/23/2017

2010 Ford F150 Regular Cab XL Pickup 2D 6 1/2 ft..... \$8,398 / \$9,779 / \$6,375

VIN: 1FTMF1CW0AKB37077

V8, 16V, 4.6 Liter.....	Included
Automatic, 4-Spd w/Overdrive.....	Included
2WD.....	Included

*\$7,000
per Eric*

*** Equipment ***

Traction Control.....	Included
AdvanceTrac.....	Included
ABS (4-Wheel).....	Included
Air Conditioning.....	Included
Power Steering.....	Included
Tilt Wheel.....	Included
AM/FM Stereo.....	Included
Dual Air Bags.....	Included
Side Air Bags.....	Included
Head Curtain Air Bags.....	Included
Vinyl Interior.....	Included
Bed Liner.....	100 / 133 / 100
Towing Pkg.....	110 / 146 / 110
Steel Wheels.....	Included

Condition.....	Fair
Total Value without mileage.....	\$8,608 / \$10,058 / \$6,585
Mileage adjustment (50636) miles.....	\$1,756

Raceway Ford - Gary Ringo

Kelley Blue Book publication for California: 2/17/2017-2/23/2017

Values are subjective opinions. Kelley Blue Book and vAuto, Inc. assume no responsibility for errors or omissions.

© vAuto, Inc. 2017, all rights reserved.

Raceway Ford
 5900 Sycamore Canyon Blvd
 Riverside, CA 92507
 (951) 784-1000



Date: 02/22/2017 Salesperson: Ringo, Gary
 Deal Number: 69791 FEB 22 17 10:07:05

Find Number 69791 Salesperson Ringo, Gary Date 02/22/2017
 Buyer Rubidoux Community Services District Co Buyer _____
 Address 3590 Rubidoux Blvd. City Rubidoux State CA Zip 92509
 Home (951) 684-7580 Work _____ Cell _____ Email _____
 New/Used New Stock# 17F1040 Year 2017 Make Ford Model F250 4X2 STYLESIDE P
 Mileage 0 Color Oxford White VIN# 1FTBF2A6XHEB29450

TRADE INFORMATION
 Year: 0 Make: _____ Model: _____
 VIN#: _____
 Mileage: _____ Color: _____

PRICE: \$ 34450.00
 Additional Accessories:
Truck #2

Payment Disclosure for Purchase

Interest Rate: 0.00
 Payment Frequency: Cash Deal
 Number of Payments: 0
 Days to 1st Pmnt: 0
 First Payment Date: 02/22/2017
 Payment/Amt Due: 0 26,028.91

Disclosure Summary for Purchase

Price	34,450.00
Less Discount	-10,066.00
Vehicle Price	24,384.00
Trade Value	10,000.00
Trade Difference	14,384.00
Accessories	5,888.82
Sub Total	20,272.82
Tax	2,352.34
Documentation Fee	80.00
Service Contract	3,315.00
	0.00
Trade Payoff	0.00
TriVIN Fee	0.00
License Fees	0.00
Title/Reg Fees	0.00
Tire Fee	8.75
Smog Fee	0.00
Total	26,028.91
Less Down Payment	0.00
Amount Due	26,028.91

Salesperson cannot accept this offer or obligate seller in any manner whatsoever. THIS OFFER IS NOT BINDING UNTIL ACCEPTED IN WRITING BY OFFICER OR SALES MANAGER OF DEALERSHIP



Disclaimer: This window sticker is only representative of the information contained on an actual window sticker, and may or may not match the actual window sticker on the vehicle itself. Please see your retailer for further information.

Vehicle Description

VIN 1FTBF2A6XHE B29450

F-SERIES 2017 F250 4X2 SD R/C
SD 6.2L EFI V-8 ENGINE
 6 SPEED AUTOMATIC TRANS G

Exterior
 OXFORD WHITE
Interior
 MEDIUM EARTH GRAY VINYL 40/20/40 SEATS

Standard Equipment INCLUDED AT NO EXTRA CHARGE

EXTERIOR

- . DOOR HANDLES - BLACK
- . LOCKING REMOVABLE TAILGATE
- . PICKUP BOX, TIE DOWN HOOKS
- . SPARE TIRE AND WHEEL LOCK
- . TOW HOOKS

INTERIOR

- . DRIVER SEAT-MANUAL LUMBAR
- . PARTICULATE AIR FILTER
- . VINYL SUN VISORS

FUNCTIONAL

- BRAKING SYSTEM
- . JEWEL EFFECT HEADLAMPS
- . TWIN I-BEAM INDEPENDENT

SAFETY/SECURITY

- . AIRBAGS - SAFETY CANOPY
- . DRIVER/PASSENGER AIR BAGS
- . SOS POST CRASH ALERT SYS

WARRANTY

- . 5YR/60,000 POWERTRAIN

- . BOX RAIL/TAILGATE MOLDINGS
- . HEADLAMPS -WIPER ACTIVATED W/LIFT ASST-NA W/BOX DLT
- NA W/BOX DLT
- NA W/BOX DLT
- . TRAILER SWAY CONTROL
- . AIR COND, MANUAL FRONT
- . OUTSIDE TEMP DISPLAY
- . TILT/TELESCOPE STR COLUMN
- . 4-WHEEL ANTI-LOCK DISC
- . HILL START ASSIST
- . MYKEY
- FRT SUSPENSION W/STAB BAR
- . ADVANCETRAC WITH RSC
- . BELT-MINDER CHIME
- . SECURILOCK PASS ANTI THEFT
- . 3YR/36,000 BUMPER / BUMPER
- . 5YR/60,000 ROADSIDE ASSIST

Price Information
STANDARD VEHICLE PRICE

MSRP
\$32,535

Optional Equipment

- 2017 MODEL YEAR
- OXFORD WHITE
- MEDIUM EARTH GRAY VINYL PREFERRED EQUIPMENT PKG.600A
- .XL TRIM
- .TRAILER TOWING PACKAGE
- .AIR CONDITIONING -- CFC FREE
- .6.2L EFI V-8 ENGINE
- 6 SPEED AUTOMATIC TRANS G
- .LT245/75R17E BSW ALL SEASON
- 3.73 RATIO REGULAR AXLE
- JOB #1 ORDER
- XL DECOR PACKAGE
- 9950# GVWR PACKAGE
- 50 STATE EMISSIONS
- SPARE TIRE AND WHEEL JACK
- XL VALUE PACKAGE 720
- .CRUISE CONTROL
- .AM/FM STEREO CD/CLK

TOTAL VEHICLE & OPTIONS	33,255
DESTINATION & DELIVERY	1,195
TOTAL MSRP	\$34,450

Disclaimer: Option pricing will be blank for any item that is priced as 0 or "No Charge".



CITY MPG
0
HIGHWAY MPG
0

Estimated Annual Fuel Cost: \$

Vehicle Engine Information

Actual mileage will vary with options, driving conditions, driving habits and vehicle's condition. Results reported to EPA indicate that the majority of vehicles with these estimates will achieve between _ and _ mpg in the city and between _ and _ mpg on the highway. For Comparison Shopping all vehicles classified as have been issued mileage ratings from _ to _ mpg city and _ to _ mpg highway.



Ford Extended Service Plan is the ONLY service contract backed by Ford and honored by the Ford and Lincoln dealers. Ask your dealer for prices and additional details or see our website at www.Ford-ESP.com.



HARBOR TRUCK BODIES, INC.
 255 VOYAGER AVENUE
 BREA, CA 92821
 (714) 996-0411 • (800) 433-9452
 FAX (714) 996-0695

SCHED. SHIP DATE WEEK OF	PAGE NO.	ORDER NO.	CANCELLATION DATE	CUST. NO.
	1	75058	02/09/18	FLR03

SALES ORDER

S
O
L
D
T
O

RACEWAY FORD-GARY
 DEALER# 71G154
 5900 SYCAMORE CYN. BLVD.
 RIVERSIDE, CA 92507

S
H
I
P
T
O

RACEWAY FORD
 DEALER# 71G154
 5900 SYCAMORE CYN. BLVD.
 RIVERSIDE, CA 92507

ORDER DATE 02/09/17	PURCHASE ORDER NO.	SHIP VIA HARBOR	F.O.B. ORIENTATION	TERMS NET 30		
BUYER GARY	12/31/44	LOCATION WHSE1	SALESPERSON FORD - LA - SOUTH	TERRITORY SOUTHERN CALIF		
ITEM NO. BIN LOCATION NO.	DESCRIPTION	QUANTITY ORDERED	QUANTITY BACK ORD.	QUANTITY SHIPPED	UNIT PRICE	EXTENSION
FORD-056-R-SRW	FORD F250/F350-REGULAR CAB VIN: MODEL YEAR: 2017 GAS ENGINE DEALER CHASSIS	1				
HT098-1541A	TRADEMASTER 8'-VERT 2 SDS STAINLES TOP 9BLX79W CPT-15DX41H-OT FL-49W CA56SRW	1			4702.06	4702.06
D30-HANDLE	MASTER LOCK-98" BODIES-HANDLE STYLE Incl Harbor Std Lock-Not Push-But or AOK	1			836.83	836.83
Y08AWHITE	PAINT FACTORY WHITE - 8-FT TRADEMASTER	1				
Z08/BRL79-08-LED	MOUNT 8-FT BODY W/BRL79-08 RECESS BUMPER LED SYS-STOP/TAIL/TURN/BACKUP/LIC	1			119.93	119.93
SUB TOTAL 5658.82 KIMBERLY/SALES		Please sign below to confirm that you have authorized the purchase of all of the above items at the prices shown. This purchase is subject to all terms and conditions noted on the reverse side of the Customer Receipt Copy.			WORK ORDER NO. 75058	5658.82 TOTAL ORDER VALUE
Authorized Signature		Date	Purchase Order No.		588882	

*add Wise Table
 + 230.00
 588882*

ORIGINAL

Lending/Retail/Auction Breakdown

Kelley Blue Book

2/17/2017-2/23/2017

2011 Ford F250 Super Duty Regular Cab XL Pickup 2D 8 ft..... \$11,639 / \$14,256 / \$9,332

VIN: 1FDBF2A63BEA85357

V8, Flex Fuel, 6.2 Liter.....	Included
Automatic, 6-Spd w/Overdrive & SelectShift.....	Included
2WD.....	Included
Ext. Color: White.....	-200 / -261 / -200

*** Equipment ***

Hill Start Assist Control.....	Included
Traction Control.....	Included
AdvanceTrac.....	Included
ABS (4-Wheel).....	Included
Anti-Theft System.....	Included
Air Conditioning.....	Included
Power Steering.....	Included
Tilt & Telescoping Wheel.....	Included
AM/FM Stereo.....	Included
Dual Air Bags.....	Included
Side Air Bags.....	Included
Head Curtain Air Bags.....	Included
Towing Pkg.....	Included
Steel Wheels.....	Included

*\$10,000
Per Eric*

Condition.....	Fair
Total Value without mileage.....	\$11,439 / \$13,995 / \$9,132
Mileage adjustment (70503) miles.....	\$609

Raceway Ford - Gary Ringo

Kelley Blue Book publication for California: 2/17/2017-2/23/2017

Values are subjective opinions. Kelley Blue Book and vAuto, Inc. assume no responsibility for errors or omissions.
© vAuto, Inc. 2017, all rights reserved.

**F-250 Styleside Pickup/Pickup Box Delete⁽¹⁾**

2017 F-250/F-350/F-450 Super Duty Pickups

Specs > Standard Equipment

DRIVE:		4x2	4x4
POWERTRAIN:		Refer to the Ordering Guide for 50 States Usage	
Engine	Type	6.2L flex-fuel V8	
Transmission	Type	TorqShift Automatic	
	Speeds	6-speed TorqShift-G SelectShift with Tow/Haul Mode	
Transfer Case	Type	—	Part-time, 2-speed
	Low/High Gear Ratio	—	2.64:1/1.00:1
AXLES:			
Front Axle	Type	Twin I-beam IFS, Ford	Monobeam, Dana Super 60
	Capacity (Rating @ Ground)	5250 lbs.	6000 lbs.
	Hubs Type	—	Manual Locking
Rear Axle	Type — Full-floating	Ford Sterling	Full Float Beam 10.5"
	Capacity (Rating @ Ground)	6200 lbs.	
BRAKES:			
Front/Rear Disc	Type	Dual-piston Pin-slider Calipers, Bolt-on Adapters, Wraparound Tie Bars	
	Rotor Diameter — Front/Rear (in.)	14.29/14.29	
Power Assist Unit	Type	Vacuum Boost	
	Effective Diameter (in.)	10.0	
Anti-Lock Braking System		4-wheel (4-channel); AdvanceTrac with RSC (Roll Stability Control)	
Parking Brake (Rear Brakes) (in.)		9.06 Drum-In-Hat (Foot-operated, Hand Release)	
ELECTRICAL:			
Alternator	Rating	157-AH, 2100 Watts (gas); 200-AH (gas); 240-AH with Gas; 175-AH (diesel); (single 220-AH or dual-combined 377-AH opt with 6.7L V8 Diesel)	
Battery	Type	Maintenance-free	
	Rating	72-AH, 650 CCA (XL, gas); single 78-AH, 750 CCA (NA XL); dual 78-AH, 750 CCA, 12-volt; dual w/Gas (opt), 6.7L Diesel (Std)	

Harnesses	Type	Trailer 7/4-wire Harness and Connector/Trailer Brake Wiring/Feed Kit (In-cab, No Controller)	
FUEL TANK:	Capacity (gal.)	Gasoline: 34.0 (142", 148", 164", 160" WB), 48.0 (176" WB) Diesel: 29.0 (142", 148" WB), 34.0 (164", 160" WB), 48.0 (176" WB)	
JACK:	Capacity	2-ton	
STEERING:	Type	Hydraulic Power-assisted steering with Recirculating Ball Gear and steering damper	
	Ratio	Variable	
SUSPENSION:			
Frame	Type	Ladder-type, 50,000 psi Steel (95% of frame); fully boxed frame	
	Section Modulus (cu. in.) ⁽²⁾	10.7	
Springs, Front	Type	Coil, Computer-selected	
	Rating @ Ground (min.)	Refer to Weight Ratings for usage and ratings	
Springs, Rear	Type	Leaf, Two-stage Variable-rate Main, Optional Leaf, Two-stage Variable	
	Rating @ Ground (min.)	Refer to Weight Ratings for usage and ratings	
Shock Absorbers	Gas-type (in.)	1.38	
Stabilizer Bar	Front/Rear (mm)	34/22	28/22 (rear opt on SRW)
TIRES:	Type	Steel-belted Radial, All-season, BSW	
	Size	Refer to tire specifications section	
	Spare Tire Carrier	Rear Underframe, Crank-down Type (Includes Lock)	
WHEELS:	Type and Size	Five, 8-hole Disc, 17" x 7.5" J steel	

(1) Available with Regular Cab, 164" WB SuperCab and 176" WB Crew Cab with 6.2L. Pickup Box Delete option allows aftermarket installation of a second unit body. For details refer to the Ford Body Builders Layout Book.

(2) 95% of full frame.



NOTE: Refer to Weight Ratings for Standard and Available Weight Rating Specifications (GVWR/Payload/Spring and GAWR/Base Curb Weight).

NOTE: For product features, please see Models & Packages and/or the Dealer Ordering Guide for availability.

Rubidoux Community Services District

SUNRISE Ford
 20 Years of service
 16005 Valley Blvd.
 Fontana, CA 92335

Joel R. Dobos
 Commercial Fleet Manager
 Direct: 909-822-4401 ext. 2171
 Cell: 909-452-0004
 Fax: 909-822-4199
 jdobos@sunriseford.com

Handwritten initials/signature

Water Resource Management Refuse Collection Street Lights Fire / Emergency Services Weed Abatement

RECEIVED
 FEB 21 2017
 BY: _____

12:48 PM PJ

Hand Carried February 8, 2017

SUBJECT: Request for Quotation - Two (2) New 2016 or 2017, ¾ Ton, 9,000 GVW or equivalent, 8 Ft Utility Bed Trucks, Two-Wheel Drive, V8, Automatic.

Dear Sir or Madame:

The Rubidoux Community Services District (District) is requesting a proposal for the purchase of two (2) new (2016 or 2017 Model Year) Two-Wheel Drive, V8, Automatic, ¾ Ton Utility Bed Trucks. The District, a public agency located in the County of Riverside, California, is eligible for all Standard Governmental Service Fleet Pricing and Warranties.

NOTE: IT IS THE INTENT OF THE DISTRICT TO TAKE DELIVERY "OFF THE LOT" RATHER THAN ORDER THE VEHICLE.

Winning bidder must be able to deliver the vehicle within 2 weeks or earlier of the award date of March 3, 2017. Delivery date of March 17, 2017 or earlier.

Dealers should submit Bids to Rubidoux Community Services District, based on the attached specifications, no later than 4:00 PM on Wednesday, February 22, 2017.

Should you have any questions, please do not hesitate to contact me directly at the District office.

Sincerely,

Brian Jennings
 Manager Budgeting and Accounting

BJA 85357

Q4791

Attachments:
 Minimum Specification Sheet(s) Truck #1 and Truck #2
 Quote Sheet(s) Truck #1 and Truck #2

Rubidoux Community Services District is a public agency located in the County of Riverside, California, and is eligible for all Standard Governmental Service Fleet Pricing and Warranties.

Additional equipment and/or upgraded modification should be listed as a separate item to allow an accurate and effective evaluation of submitted bids. All modifications to the minimum specifications, as stated above, shall be clearly identified. The quote should have 150,000 mile, 5 year, 6,000 engine hour extended warranties that should also be included in the submitted proposal and options for the vehicle.

The vehicle quoted price shall include all applicable state and local taxes, licenses, dealer transportation and preparation fees. Vehicles shall be "Highway Ready" with registration plates being filed "Exempt" by the dealer(s) with the Department of Motor Vehicles.

The above vehicles shall be fully fueled and lubricated.

RUBIDOUX COMMUNITY SERVICES DISTRICT

QUOTATION REQUEST

The Rubidoux Community Services District is requesting quotations to furnish and deliver equipment as described per attached District standard vehicle specification. Note: The total price quoted shall include all applicable taxes and delivery cost. "E" license are required.

<u>Term</u>	(1) Model Year 2016 or 2017, 3/4 Ton 9,000 GVW or equivalent 8 FT Utility Bed Truck (Truck #1)	PRICE \$ <u>30039.65</u>
<u>Warranty</u>	150,000 Miles/5 Year; 6,000 Engine Hour (Extended Warranty)	\$ <u>2265⁰⁰</u>
	BASE CASE	df TAX \$ <u>2452.02</u>
<u>Trade In Item</u>	2009 Ford F150 PickUp VIN # 1FTMF1CW0AKB37077 Approximately 52,000 miles	\$(<u>6000⁰⁰</u>)
		TOTAL \$ <u>28756.67</u>

The intended target vehicle is a ¾ ton, 4x2 Truck, V8, automatic. It is preferred that the winning bidder be able to deliver the vehicle within 2 weeks or earlier of the award date. Otherwise bidder need provide best estimate of delivery date in bid quote.

The equipment quoted shall be furnished in compliance with the State of California Air Resource Board standards and as comparable to the attached specification sheets **for delivery by March 17, 2017 or earlier.**

Proposals should arrive at the District office no later than 4:00 pm, Wednesday, February 22, 2017. It is anticipated that the District shall award the contract at the regularly scheduled meeting of the Board of Directors, March 2, 2017. The District will issue to the awarded dealer a Purchase Order for the vehicle the day following Board approval. Upon vehicle delivery

#1
 Rubidoux Community Services District is a public agency located in the County of Riverside, California, and is eligible for all Standard Governmental Service Fleet Pricing and Warranties.

Additional equipment and/or upgraded modification should be listed as a separate item to allow an accurate and effective evaluation of submitted bids. All modifications to the minimum specifications, as stated above, shall be clearly identified. The quote should have 150,000 mile, 5 year, 6,000 engine hour extended warranties that should also be included in the submitted proposal and options for the vehicle.

The vehicle quoted price shall include all applicable state and local taxes, licenses, dealer transportation and preparation fees. Vehicles shall be "Highway Ready" with registration plates being filed "Exempt" by the dealer(s) with the Department of Motor Vehicles.

The above vehicles shall be fully fueled and lubricated.

RUBIDOUX COMMUNITY SERVICES DISTRICT

QUOTATION REQUEST

The Rubidoux Community Services District is requesting quotations to furnish and deliver equipment as described per attached District standard vehicle specification. Note: The total price quoted shall include all applicable taxes and delivery cost. "E" license are required.

<u>Term</u>	(1) Model Year 2016 or 2017, 3/4 Ton 9,000 GVW or equivalent 8 FT Utility Bed Truck (Truck #1)	PRICE \$ 30039.65
<u>Warranty</u>	150,000 Miles/5 Year; 6,000 Engine Hour (Extended Warranty) XTRA CARE	\$ 2580 ⁰⁰ df TAX \$ 245202
<u>Trade In Item</u>	2009 Ford F150 PickUp VIN # 1FTMF1CW0AKB37077 Approximately 52,000 miles	\$(6000 ⁰⁰) TOTAL \$ 29071.67

The intended target vehicle is a ¾ ton, 4x2 Truck, V8, automatic. It is preferred that the winning bidder be able to deliver the vehicle within 2 weeks or earlier of the award date. Otherwise bidder need provide best estimate of delivery date in bid quote.

The equipment quoted shall be furnished in compliance with the State of California Air Resource Board standards and as comparable to the attached specification sheets **for delivery by March 17, 2017 or earlier.**

Proposals should arrive at the District office no later than 4:00 pm, Wednesday, February 22, 2017. It is anticipated that the District shall award the contract at the regularly scheduled meeting of the Board of Directors, March 2, 2017. The District will issue to the awarded dealer a Purchase Order for the vehicle the day following Board approval. Upon vehicle delivery

TRUCK # 1

and acceptance by the District, payment shall be made in full to the selected dealer within thirty (30) calendar days.

The District reserves the right to reject any and all bids received.

Written proposals should be submitted to: Attn: Brian Jennings
Rubidoux Community Services District,
3590 Rubidoux Blvd.
Jurupa Valley, California 92509

Faxed proposals may be transmitted to RCSD Attn: Brian Jennings at (951) 369-4061.

Said envelope shall also contain the following in the lower left-hand corner thereof:

Proposal of _____ (Name of Bidder) SUNRISE FORD

For: One (1) Model Year 2016 or 2017, 3/4 Ton, 8 Ft Utility Truck Bid (Truck #1)

Signed: [Signature]
SOEL DOBOS

Company: SUNRISE FORD

Title: FLEET MANAGER

Address: 16005 Valley Blvd
Fo

Date: 2-21-17

City: FORTIANA CA

Estimated Delivery Date: APRIL 1
2017

909 822
4401
x2171

Truck #
2 WARRIOR \$
1 BASE
1 XTRA

Rubidoux Community Services District

Board of Directors

Christopher Barajas
Armando Muniz
Bernard Murphy
F. Forest Trowbridge
Ruth Anderson Wilson



1
#2

Secretary-Manager

David D. Lopez

Water Resource Management Refuse Collection Street Lights Fire / Emergency Services Weed Abatement

February 8, 2017

SUBJECT: Request for Quotation - Two (2) New 2016 or 2017, ¾ Ton, 9,000 GVW or equivalent, 8 Ft Utility Bed Trucks, Two-Wheel Drive, V8, Automatic.

Dear Sir or Madame:

The Rubidoux Community Services District (District) is requesting a proposal for the purchase of two (2) new (2016 or 2017 Model Year) Two-Wheel Drive, V8, Automatic, ¾ Ton Utility Bed Trucks. The District, a public agency located in the County of Riverside, California, is eligible for all Standard Governmental Service Fleet Pricing and Warranties.

NOTE: IT IS THE INTENT OF THE DISTRICT TO TAKE DELIVERY "OFF THE LOT" RATHER THAN ORDER THE VEHICLE.

Winning bidder must be able to deliver the vehicle within 2 weeks or earlier of the award date of March 3, 2017. Delivery date of March 17, 2017 or earlier.

Dealers should submit Bids to Rubidoux Community Services District, based on the attached specifications, no later than 4:00 PM on Wednesday, February 22, 2017.

Should you have any questions, please do not hesitate to contact me directly at the District office.

Sincerely,

Brian Jennings
Manager Budgeting and Accounting

BJA 65357

Q4791

Attachments:

Minimum Specification Sheet(s) Truck #1 and Truck #2
Quote Sheet(s) Truck #1 and Truck #2

Rubidoux Community Services District is a public agency in California, and is eligible for all Standard Government

Additional equipment and/or upgraded modification an accurate and effective evaluation of submitted bid specifications, as stated above, shall be clearly identified. Mile, 5 year, 6,000 engine hour extended warranties submitted proposal and options for the vehicle.

SUNRISE Ford
20 Years of service

Joel R. Dobo
Commercial Fleet Manager
Direct: 909-822-4401 ext.
Cell: 909-452-0
Fax: 909-822-4
jdobo@sunriseford.com

16005 Valley Blvd
Fontana, CA 92335

The vehicle quoted price shall include all applicable state and local taxes, licenses, dealer transportation and preparation fees. Vehicles shall be "Highway Ready" with registration plates being filed "Exempt" by the dealer(s) with the Department of Motor Vehicles.

The above vehicles shall be fully fueled and lubricated.

RUBIDOUX COMMUNITY SERVICES DISTRICT

QUOTATION REQUEST

The Rubidoux Community Services District is requesting quotations to furnish and deliver equipment as described per attached District standard vehicle specification. Note: The total price quoted shall include all applicable taxes and delivery cost. "E" license are required.

<u>Term</u>	(1) Model Year 2016 or 2017, 3/4 Ton 9,000 GVW or similar 8 FT Utility Bed Truck (Truck #2)	PRICE \$ 30039.65
<u>Warranty</u>	150,000 Miles/5 Year; 6,000 Engine Hour (Extended Warranty)	\$ 2265.00
<u>BASE CAR</u>		TAX \$ 2334.27
<u>Trade In Item</u>	2011 Ford F250 Utility Bed VIN # 1FDBF21A63BEA85357 Approximately 72,000 miles	(\$ 8000.00)
		TOTAL \$ 26756.67

The intended target vehicle is a 3/4 Ton, 4x2 Truck, V8, automatic. It is preferred that the winning bidder be able to deliver the vehicle within 2 weeks or earlier of the award date. Otherwise bidder need provide best estimate of delivery date in bid quote.

The equipment quoted shall be furnished in compliance with the State of California Air Resource Board standards and as comparable to the attached specification sheets for delivery by **March 17, 2017 or earlier.**

Proposals should arrive at the District office no later than 4:00 pm, Wednesday, February 22, 2017. It is anticipated that the District shall award the contract at the regularly scheduled meeting of the Board of Directors, March 2, 2017. The District will issue to the awarded dealer a Purchase Order for the vehicle the day following Board approval. Upon vehicle delivery

TRUCK #2

Rubidoux Community Services District is a public agency located in the County of Riverside, California, and is eligible for all Standard Governmental Service Fleet Pricing and Warranties.

Additional equipment and/or upgraded modification should be listed as a separate item to allow an accurate and effective evaluation of submitted bids. All modifications to the minimum specifications, as stated above, shall be clearly identified. The quote should have 150,000 mile, 5 year, 6,000 engine hour extended warranties that should also be included in the submitted proposal and options for the vehicle.

The vehicle quoted price shall include all applicable state and local taxes, licenses, dealer transportation and preparation fees. Vehicles shall be "Highway Ready" with registration plates being filed "Exempt" by the dealer(s) with the Department of Motor Vehicles.

The above vehicles shall be fully fueled and lubricated.

RUBIDOUX COMMUNITY SERVICES DISTRICT

QUOTATION REQUEST

The Rubidoux Community Services District is requesting quotations to furnish and deliver equipment as described per attached District standard vehicle specification. Note: The total price quoted shall include all applicable taxes and delivery cost. "E" license are required.

<u>Term</u>	(1) Model Year 2016 or 2017, 3/4 Ton 9,000 GVW or similar 8 FT Utility Bed Truck (Truck #2)	PRICE \$ <u>30039.65</u>
<u>Warranty</u>	150,000 Miles/5 Year; 6,000 Engine Hour (Extended Warranty) XTRA CARE FORM	\$ <u>2580</u> TAX \$ <u>2334.27</u>
<u>Trade In Item</u>	2011 Ford F250 Utility Bed VIN # 1FDBF21A63BEA85357 Approximately 72,000 miles	\$(<u>8000⁰⁰</u>) TOTAL \$ <u>27071.67</u>

The intended target vehicle is a ¾ Ton, 4x2 Truck, V8, automatic. It is preferred that the winning bidder be able to deliver the vehicle within 2 weeks or earlier of the award date. Otherwise bidder need provide best estimate of delivery date in bid quote.

The equipment quoted shall be furnished in compliance with the State of California Air Resource Board standards and as comparable to the attached specification sheets **for delivery by March 17, 2017 or earlier.**

Proposals should arrive at the District office no later than 4:00 pm, Wednesday, February 22, 2017. It is anticipated that the District shall award the contract at the regularly scheduled meeting of the Board of Directors, March 2, 2017. The District will issue to the awarded dealer a Purchase Order for the vehicle the day following Board approval. Upon vehicle delivery

TRUCK # 2

and acceptance by the District, payment shall be made in full to the selected dealer within thirty (30) calendar days.

The District reserves the right to reject any and all bids received.

Written proposals should be submitted to: Attn: Brian Jennings
Rubidoux Community Services District,
3590 Rubidoux Blvd.
Jurupa Valley, California 92509

Faxed proposals may be transmitted to RCSD Attn: Brian Jennings at (951) 369-4061.

Joel
Dobos

Said envelope shall also contain the following in the lower left-hand corner thereof:

Proposal of 2017 3/4 Service Truck (Name of Bidder) SUNRISE FORN

For: One (1) Model Year 2016 or 2017, 3/4 Ton, 8 Ft Utility Truck Bid (Truck #2)

Signed: [Signature]

Company: SUNRISE FORN

Title: Fleet Manager

Address: 16005 Valley Blvd

Date: 2-21-17

City: Fontana CA 92335

Estimated Delivery Date: April 1 2017

909 822
4401

TO: Rubidoux Community Services District
Attn: Brian Jennings
Manager Budgeting and Accounting
3590 Rubidoux Blvd., Jurupa Valley, CA 92509

February 10, 2017

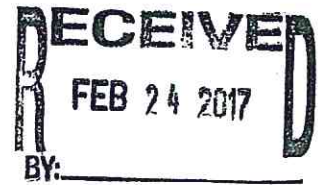

FROM: Gonzalo Estrada-Llamas
Commercial Vehicles and BusinessLink Representative
Browning Chrysler, Dodge, Jeep, Ram
1983 Hamner Ave., Norco, CA 92860

RE: Request fro Quotation - Two New 2016 or 2017, 3/4 Ton, 9,000LB GVW or equivalent, 8 ft Utility Bed Trucks, Two-Wheel Drive, V8 Automatics.

We regret to inform you that Browning Chrysler, Dodge, Jeep, Ram of Norco cannot participate in the above cited bid due to the fact that we do not have the requested vehicles IN STOCK at this time.

Due to the type of specialized vehicles the District is seeking, we typically order them at the time of request of our clients and not as on hand stock.

If the Board of Directors decides to consider placing a special order, we would be glad to participate in a bid, with the time considerations required for a custom order.

We wish you the best in this process and hope that if you decide to place a custom order, you will give us the opportunity to bid.

Respectfully.

Gonzalo Estrada-Llamas
Commercial Vehicles and BusinessLink Representative
Browning Dodge of Norco
(951)817-5526, gestrada@browningautogroup.com

11. CONSIDERATION TO AUTHORIZE THE APPLICATION FOR
DISTRICT CREDIT CARD FOR RCSD PURPOSES: **DM 2017-10**

Rubidoux Community Services District

Board of Directors

Christopher Barajas
Armando Muniz
Bernard Murphy
F. Forest Trowbridge
Ruth Anderson Wilson

Secretary-Manager

David D. Lopez



Water Resource Management

Refuse Collection

Street Lights

Fire / Emergency Services

Weed Abatement

DIRECTORS MEMORANDUM 2017-10

March 2, 2017

To: Rubidoux Community Services District
Board of Directors

Subject: Authorize the Application of District Credit Card

BACKGROUND:

On a limited basis the Rubidoux Community Services District has a need to purchase goods and services via a credit card when suppliers, vendors and seminars do not take a District issued purchase order (P.O.). Typical credit card purchases include Board Members seminar registrations, employee training and workshops, annual employee banquet and in-house working lunches to name a few. In all of the above purchases, District employees use personal credit cards for District related services and goods. Employees are then required to complete and submit a reimbursement request for District related expenses and must now wait for Board approval. As a disclosure, the District does have a Home Depot credit card for materials and hand tools. The Home Depot card is controlled by our Manager of Fiscal Services and requested by the District Field Manager when needed.

A District Credit card would eliminate the use of employee's personal credit card purchases. Further, a District Credit Card authorization provides a mechanism which improves the efficiency and convenience of conducting District business. Staff would recommend the issuance of two (2) Credit cards – one to the Manager of Fiscal Services and the other to our District Engineer/Assistant General Manager. For checks and balances purposes, the General Manager would not be a bearer to any proposed District credit card.

Staff has reviewed three (3) potential credit cards; Capital One, Chase and CSDA. It is our recommendation based upon the limited and selective use of a District issued credit card that Chase Credit Card offers the best benefits since it offers a 5% cash back on the first \$25,000.00 on an annual basis.

RECOMMENDATION:

Staff recommends to the Rubidoux Community Services District Board of Directors the authorization to apply for the Chase Credit Card for District use. If the Board concurs, Staff request authorization to amend Draft Resolution No. 2017-833 at the next regular Board Meeting of the Rubidoux Community Services District for Adoption to effectuate the application of District Credit Card(s).

Respectfully,

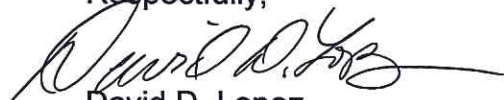

David D. Lopez
Secretary Manager

Attachments: Credit Card Summary and Matrix
Draft Resolution No. 2017-833

RCSA Credit Card Analysis

<u>Capital One</u>	<u>Chase</u> *	<u>CSDA</u>
No Annual Fee	No Annual Fee	potential \$30 annual fee
0% APR until October 2017	0% intro APR for 12 months from account opening on purchases and balance transfers.	No introductory rate
Annual APR depending on credit - 13.24% / 17.24% / 21.24%	13.74%–19.74% variable APR.	APR - Prime (currently 3.75%) + 4.99%
\$39 Late Fee	\$39 Late Fee	\$25 Late Fee
1.5% cash back, no limit on the amount of cash back earned	Earn 5% cash back on the first \$25,000 spent in combined purchases at office supply stores and on cellular phone, landline, internet and cable TV services each account anniversary year.* Earn 2% cash back on the first \$25,000 spent in combined purchases at gas stations and restaurants each account anniversary year.* Earn 1% cash back on all other purchases—with no limit to the amount you can earn.*	No minimum spend to earn rebates - paid annual based upon District's share of CSDA volume
\$500 one-time cash-back bonus (spend \$4500 on purchases within first 3 months of approval)	\$300 one-time cash-back bonus (spend \$3000 on purchases within first 3 months after account opening)	Consolidated annual spending of card participants - min avg \$20k per month - if fall below consolidated spending of \$20k per month, an annual card fee of \$30 could apply for each participating District.
Cash rewards don't expire	Cash rewards don't expire	Rebates paid annually within 30 days after the end of each calendar year of the Agreement
\$0 Fraud Liability if card lost or stolen		Up to \$100,000 Protection against Employee Misuse
90-Day Purchase Protection on most purchases in the event of loss, theft, damage or fire		60-Days to dispute a transaction
Employee cards at no additional cost	Employee cards at no additional cost	

Draft

RESOLUTION NO. 2017-833

RESOLUTION OF THE BOARD OF DIRECTORS
OF THE RUBIDOUX COMMUNITY SERVICES DISTRICT
ADOPTING CREDIT CARD POLICY

WHEREAS, Credit Cards are mechanisms for purchasing good and services for the convenience of the Rubidoux Community Services District; and

WHEREAS, the Rubidoux Community Services District Board deems that it is in the best interest of the District to make certain District financial transactions by using a credit card as described in the attached Credit Card Policy and marked as Exhibit "A",

NOW THEREFORE BE IT RESOLVED BY THE BOARD OF DIRECTORS OF THE RUBIDOUX COMMUNITY SERVICES DISTRICT ("DISTRICT") the Credit Card Policy developed by Staff and presented on March 2, 2017, be adopted as the Rubidoux Community Services District Policy and directs the following actions:

Section 1. Authorize the application for credit cards;

Section 2. Authorize the General Manager to negotiate and execute any necessary agreements, approved as to legal form;

Section 3. Authorize no more than two (2) credit cards for District use.

BE IT FURTHER RESOLVED that this Resolution was approved and adopted this 2nd day of March, 2017, at the Regular Meeting of the Board of Directors of the Rubidoux Community Services District by the following vote:

AYES:
NOES:
ABSENT:
ABSTENTIONS:

Armando Muniz, President

(Seal)

ATTEST:

David D. Lopez
Secretary to the Board

APPROVED AS TO FORM AND CONTENT:

John R. Harper, District Counsel

Exhibit "A"

RUBIDOUX COMMUNITY SERVICES DISTRICT

CREDIT CARD POLICY

Purpose

- Ensure that District Purchasing Card transactions are carried out as effectively as possible.
- Guard against any possible fraud and abuse of the District Purchasing Card.

Authority

General Manager, Manager of Fiscal Services, and Accounting/Budgeting Manager are responsible to ensure that the District Purchasing Card expenses are proper and reimbursable under this policy and that the expenses are reasonable and necessary. Final approval of reimbursements is under the authority of the Board.

Procedures

Card Issue

- The Rubidoux CSD provides staff with a District Purchasing Card for purchases of goods and services.
- Each District Purchasing Card has a monthly spending limit. This limit is based upon anticipated purchasing needs and is set and authorized by the General Manager and/or the Manager of Fiscal Services.

Credit Card Expenditure

- The District Purchasing Card will only be used for those activities that are direct consequences of the cardholders' function within the organization.
- Any purchase over the amount of \$250 requires written approval from the General Manager or Manager of Fiscal Services.

Cardholder's Responsibilities

- Activate and sign the back of the District Purchasing Card as soon as it is received.
- When a purchase is made, the following information should be recorded on the physical receipt:
 - If the expenditure is for a specific grant project – note the Grant Name
 - If the expenditure is for RCSD Indirect or Operating Expenses – note the budget category (Operating Supplies, Utilities, etc.)
 - Describe what was purchased – if this is not already clearly indicated on the receipt.
 - Write cardholder's name or initials on the receipt
 - Give the receipt to the Accounting/Budgeting Manager immediately.

- If the District Purchasing Card is lost or stolen report this immediately, no later than the next business day, to the Accounting/Budgeting Manager or Manager of Fiscal Services so that the Card can be cancelled.
- Review and sign a copy of the monthly statement to verify all the transactions are correct and have been made for official purposes.
- In the event of resignation, return the District Purchasing Card to the Manger of Fiscal Services.
- Cardholder shall be personally liable for any unauthorized transactions unless the Card is lost, stolen, or subject to fraud by a third party.

District Purchasing Card Policy Employee Acknowledgement

Cardholder's Name: _____

Position: _____

Card Limit: _____

I agree to the following:

- I have read and understand the District Purchasing Card Use Policy.
- The District Purchasing Card is the property of Rubidoux CSD.
- It must be kept in the District's vault under strict control by the Manger of Fiscal Services.
- I will not permit the District Card to be used by any person other than myself.
- I will only use the District Card for official purposes and in accordance with this policy.
- I will immediately report any unauthorized use of the District Card.
- I will be personally liable for any unauthorized transactions unless the District Card is lost, stolen or subject to fraud by a third party.

Name

Date

12. DIRECTORS COMMENTS – NON-ACTION

13. ADJOURNMENT