

# Rubidoux Community Services District

## Board of Directors

Hank Trueba Jr.  
Armando Muniz  
Bernard Murphy  
John Skerbelis  
F. Forest Trowbridge

## General Manager

Steven W. Appel



---

Water Resource Management    Refuse Collection    Street Lights    Fire / Emergency Services    Weed Abatement

## NOTICE AND AGENDA FOR THE RUBIDOUX COMMUNITY SERVICES DISTRICT BOARD MEETING 4:00 PM, September 5, 2019

1. Call to Order - President Trueba
2. Pledge of Allegiance
3. Roll Call
4. Approval of Minutes for August 15, 2019, Regular Meeting.
5. Consideration to Approve September 6, 2019, Salaries, Expenses and Transfers.
6. Acknowledgements - Members of the Public May Address the Board at this Time on Any Non-agenda Matter.
7. Correspondence and Related Information
8. Manager's Report (Second Meeting each Month):
  - a) Operations Report
  - b) Emergency and Incident Report

**ACTION ITEMS:**

9. Consideration to Purchase Two Replacement (Utility Bed Trucks) and One New Fleet Vehicles (1/2-ton Pickup Truck): **DM 2019-47**
10. **CLOSED EXECUTIVE SESSION** – Pursuant to Government Code Section 54956.8:  
Real Property Negotiations.  
Property: 5293 Mission Blvd, Jurupa Valley, CA  
Agency negotiator: Steven Appel  
Under negotiation: Purchase/No purchase, price, and terms
11. **CLOSED EXECUTIVE SESSION** – Pursuant to Government Code Section 54956.9: Legal Counsel Status on Litigation Case No. CIVDS 1310520, City of Riverside vs. Rubidoux Community Services District
12. Directors Comments - Non-action
13. Adjournment

Closed Session: At any time during the regular session, the Board may adjourn to a closed executive session to consider matter of litigation, personnel, negotiations, or to deliberate on decisions as allowed and pursuant with the open meetings laws. Discussion of litigation is within the Attorney/Client privilege and may be held in closed session.

Authority: Government code 11126-(a) (d) (q).

4. APPROVAL OF MINUTES FOR AUGUST 15, 2019, REGULAR  
MEETING MINUTES

**MINUTES OF REGULAR MEETING**  
**August 15, 2019**  
**RUBIDOUX COMMUNITY SERVICES DISTRICT**

**DIRECTORS PRESENT:** Armando Muniz  
John Skerbelis  
F. Forest Trowbridge  
Hank Trueba, Jr.  
\*Bernard Murphy

**DIRECTORS ABSENT:**

**STAFF PRESENT:** Steve Appel, General Manager  
Jeff Sims, Assistant General Manager/District Engineer  
Brian Laddusaw, Director of Finance  
Brian Jennings, Manager Budgeting & Accounting

Call to order: the meeting of the Board of Directors of the Rubidoux Community Services District by President Trueba, at 4:00 P.M., Thursday, August 15, 2019, at the District Office, 3590 Rubidoux Boulevard, Jurupa Valley, California.

**ITEM 4. APPROVAL OF MINUTES**

Approval of Minutes for August 1, 2019, Regular Board Meeting.

**Director Muniz moved and Director Skerbelis seconded to approve August 1, 2019 Minutes.**

**Ayes – 5 (Muniz, Murphy, Skerbelis, Trowbridge, Trueba)**

**Noes – 0**

**Abstain – 0**

**The motion was carried unanimously.**

**\*Director Murphy arrived.**

**ITEM 5. Consideration to Approve the August 16, 2019 the Salaries, Expenses and Transfers.**

Consideration to approve August 16, 2019, Salaries, Expenses and Transfers.

**Director Skerbelis moved and Director Trowbridge seconded to Approve the August 16, 2019 Salaries, Expenses and Transfers.**

**Ayes – 5 (Muniz, Murphy, Skerbelis, Trowbridge, Trueba,)**

**Noes – 0**

**Abstain – 0**

**The motion was carried unanimously.**

#### **ITEM 6. PUBLIC ACKNOWLEDGE OF NON-AGENDA MATTERS**

Mr. Rudy Rodriquez, a project manager from Fullmer Construction addressed the board regarding a project on Caterpillar Ct. in Jurupa Valley. He was addressing the board on the 1991 ordinance pertaining to non-potable water being used for construction/grading usage. He requested usage of water from any of the three hydrants available on the jobsite. The nearest well is Well No. 3, 1.5 miles away. The owner will charge fees of \$20,000/mo. Mr. Appel explained the origin of the policy dating back due to infrastructures at the time. It has worked well for other contractors in the past. Mr. Rodriquez is concerned about the distance of the well to the construction site. Mr. Steve Appel stated he did not see a reason to grant a waiver for the water. These wells are identified for construction purposes. This is a matter which needs to be met with staff. Business cards were exchanged to set up a meeting.

#### **ITEM 7. CORRESPONDENCE AND RELATED INFORMATION**

The first article was from the San Gabriel Valley Tribune, regarding rePlanet closing all recycling centers, prompting a call for bottle, can redemption at stores. The next article dealt with PFAS and CA checking on “Forever Chemicals’ in drinking water. The next article from the California Water News Daily was regarding 5 Southern CA partners working to reopen the Louis Rubidoux Nature Center Consortium and Sunnyslope Creek, a degraded tributary to the Santa Ana River. The final article deals with a portion of the Santa Ana River closure due to bacteria.

#### **ITEM 8. MANAGER’S REPORT**

##### **Operations Report:**

Everything is operating normally.

##### **Emergency and Fire Report:**

The Incident Report for July 1 – July 31, 2019 there were a total of calls for Station 38. There was a total of 250 for the District, with 65% of the calls were medical aid. 216 of the 230 were from our engine for the month.

**ITEM 9. Receive and File Statement of Cash Asset Schedule Report Ending July 2019. DM 2019-45.**

**BACKGROUND**

Attached for the Board of Directors' consideration is the June 2019 Statement of Cash Asset Schedule Report for all District Fund Accounts. Our YTD interest is \$102,793.75 for District controlled accounts. With respect to District "Funds in Trust", we show \$4,737.15 which has been earned and posted. The District has a combined YTD interest earned total of \$107,530.90 as of July 31, 2019.

With respect to the District's Operating Funds (Excluding Restricted Funds and Operating Reserves), we show a balance of \$6,189,0147.25 ending July 31, 2019. That's **\$50,146.95 MORE** than July 1, 2018, beginning balance of \$6,139,000.30.

Further, the District's Field/Admin Fund current fund balance is just over \$496,047.28.

Submitted for the Board of Directors consideration is the *July 2019, Statement of Cash Asset Schedule Report* for your review and acceptance this afternoon.

**Director Muniz moved and Director Trowbridge seconded to Receive and File the Statement of Cash for the Month of July 2019 for the Rubidoux Community Services District.**

**Ayes – 5 (Muniz, Murphy, Skerbelis, Trowbridge, Trueba)**

**Noes – 0**

**Abstain – 0**

**The motion was carried unanimously.**

**ITEM 10. Annual Review of the District's Investment Policy and Designated Investment Institutions. DM 2019-46.**

**BACKGROUND**

It's been over twenty (22) years since the Board of Directors adopted a "Statement of Investment Policy" for the Rubidoux Community Services District. *As required by California Government Code Section 5334(a), the legislative body shall annually review the policy and change(s) at a public meeting.* The purpose of such annual review during a public meeting is to ensure that all investments practices meet Federal, State, and local criteria for prudent management of said local public agency assets. This annual investment policy review is a result of Orange County's Bankruptcy in December 1994.

The attached investment policy sets strategies and guidelines which diversifies assets and maximizes rates while reducing risks. The District continues to exercise most investment instruments, seeking the best yields for our monies. Conservative investment coupled with diversification in this economic environment is a prudent investment management strategy to follow when public monies are at stake. Staff does recommend adjustments,

modifications or changes to the “Statement of Investment Policy”. Those changes are summarized on Brian Laddusaw’s Memo authored on August 7, 2019.

Further, the above recommendations have been incorporated and highlighted into the Rubidoux Community Services District Investment Policy for your review. If acceptable, Resolution No. 2019-855 is presented for the Board of Directors adoption this afternoon. With respect to our banking and investment institutions, Staff is requesting to keep active, for investment purposes, those banking institutions listed on attached Resolution No. 660 and 799. Consequently, no changes are recommended this year.

Page number 3, paragraph “D”, Time Deposits: the first of a few changes. We have stricken “non-negotiable” time deposits, and “negotiable” time deposits. This was a specification that did not need to be in there. The general time deposits are adequate enough for the policy. The next change is on page 6, Roman numeral IX, Delegation of Authority; these changes recognize resolutions the board adopted earlier this year when Mr. Appel took the General Manager Role and Brian took the Director of Finance role when Krysta and Dave left the District. With Brian’s change, the change in title has been noted as well, in the same section.

**Director Skerbelis moved and Director Muniz seconded Adoption of Resolution No. 2019-855, which modifies and updates the Rubidoux Community Services District Investment Policy.**

**Ayes – 5 (Muniz, Murphy, Skerbelis, Trowbridge, Trueba)**

**Noes – 0**

**Abstain – 0**

**The motion was carried unanimously.**

**ITEM 11. CLOSED EXECUTIVE SESSION Pursuant to Government Code Section 54956.8:**

Real Property Negotiations.

Property: 5293 Mission Blvd., Jurupa Valley, CA

Agency negotiator: Steven Appel

Under negotiations: Purchase/No purchase, price, and terms

**No report at this time.**

**ITEM 12. Directors Comments.**

Director Trueba adjourned the meeting at 4:48 pm.

5. CONSIDERATION TO APPROVE SEPTEMBER 6, 2019,  
SALARIES, EXPENSES AND TRANSFERS



RUBIDOUX COMMUNITY SERVICES DISTRICT  
 SEPTEMBER 5, 2019 (BOARD MEETING)  
**FUND TRANSFER AUTHORIZATION**

<b>NET PAYROLL 9/6/19</b>	65,500.00
WIRE TRANSFER: FEDERAL PAYROLL TAXES 9/9/19	26,800.00
WIRE TRANSFER: STATE PAYROLL TAXES 9/9/19	5,700.00
WIRE TRANSFER: TO CREDIT UNION	600.00
WIRE TRANSFER: PERS RETIREMENT	17,650.00
WIRE TRANSFER: PERS HEALTH PREMIUMS	29,620.00
WIRE TRANSFER: PERS RETIRED HEALTH PREMIUMS AND FEES	2,321.00
WIRE TRANSFER: SECTION 125	70.00
WIRE TRANSFER: SECTION 457	2,320.00

**CHECKING ACCOUNT TRANSFERS FOR ACCOUNTS PAYABLE:**

9/6/2019 WATER FUND TO GENERAL FUND-Payables	328,361.56
WATER FUND TO GENERAL FUND-Trash	177,899.05
WATER FUND TO SEWER FUND	145,553.70
 SEWER FUND TO GENERAL FUND-Payables	 34,746.16

**INTERFUND TRANSFERS:**

9/6/2019 SEWER FUND CHECKING TO LAIF SEWER OP	111,684.00
SEWER FUND CHECKING TO LAIF SEWER ML	17,316.00
SEWER FUND CHECKING TO WATER FUND CHECKING	-
LAIF SEWER ML TO LAIF SEWER OP	5,697.56
LAIF SEWER OP TO LAIF WASTEWATER REPLACEMENT	-
LAIF SEWER OP TO LAIF WASTEWATER RESERVE	-
LAIF WASTEWATER RESERVE TO LAIF SEWER OP	12,335.91
GENERAL FUND CHECKING TO LAIF SEWER ML	-
GENERAL FUND CHECKING TO LAIF PROP TAX	-
GENERAL FUND CHECKING TO LAIF FIRE MITIGATION	17,000.00
GENERAL FUND PROPERTY TAX TO GF CHECKING	-
GENERAL FUND PROP TAX TO GENERAL FUND CHECKING	60,000.00
GENERAL FUND CHECKING TO SEWER FUND CHECKING	17,316.00
GENERAL FUND CHECKING TO WATER FUND CHECKING	37,214.00
LAIF GENERAL TO GENERAL FUND CHECKING	-
LAIF PROPERTY TAX TO GENERAL FUND CHECKING	98,000.00
WATER FUND CHECKING TO LAIF-COP PAYBACK	97,386.00
WATER FUND CHECKING TO LAIF-W.R.	14,400.00
WATER FUND CHECKING TO GENERAL FUND CHECKING	-
LAIF WATER ML TO LAIF WATER REPLACEMENT	-
LAIF WATER ML TO LAIF WATER OPS	5,895.00
LAIF WATER OP TO WATER FUND CHECKING	49,000.00
LAIF WATER RESERVE TO LAIF WATER OP	-
WATER FUND CHECKING TO LAIF WATER RESERVE	-
WATER FUND CHECKING TO LAIF WATER OP	970.00
WATER FUND CHECKING TO LAIF WATER ML	36,244.00

**NOTES PAYABLE**

<u>DESCRIPTION</u>	<u>BALANCE</u>		<u>PAYMENT</u>	<u>DUE DATE</u>
U.S. Bank Trust (1998 COP's Refunding)	3,660,000	Prin.	535,000	Dec-19
U.S. Bank Trust (1998 COP's Refunding)	587,520	Intr.	93,330	Dec-19
MN Plant-State Revolving Loan	4,385,106	Prin.	125,734	Jan-20
MN Plant-State Revolving Loan	895,735	Intr.	56,364	Jan-20

**AP Enter Bills Edit Report**  
**Rubidoux Community Services District (RCSACT)**  
 Batch: AAAAGY

8/28/2019 2:06:53 PM

Page 1

Tr. #	Vendor	Inv Date	Paid Out	Immediate	Credit Card Vendor	Due Date	Discount Date	Invoice #
PO Number		Inv Date	Immediate GL Account		Check #		Payment Date	Discount
GL Date		Immediate GL Account			Credit Card	CC Reference #		Total Invoice
1	AIRGAS / AIRGAS USA, LLC ✓	7/31/2019 ✓	N	N				9964041421 ✓
TNK RNTL						8/30/2019 ✓	7/31/2019	\$0.00
9/5/2019 ✓					N			\$151.34 ✓
2	AQUA METRIC SALES / AQUA METRIC SALES CO ✓	8/7/2019 ✓	N	N				INV0074667 ✓
MTR READ PROBES						9/7/2019 ✓	8/7/2019	\$0.00
9/5/2019 ✓					N			\$1,874.38 ✓
3	BABCOCK E S SONS INC / BABCOCK, E S & SONS, IN ✓	8/6/2019 ✓	N	N				BH90411-0267 ✓
WTR ANALYSES						9/6/2019 ✓	8/6/2019	\$0.00
9/5/2019 ✓					N			\$105.00 ✓
4	BABCOCK E S SONS INC / BABCOCK, E S & SONS, IN ✓	8/6/2019 ✓	N	N				BH90418-0267 ✓
WTR ANALYSES						9/6/2019 ✓	8/6/2019	\$0.00
9/5/2019 ✓					N			\$32.00 ✓
5	BABCOCK E S SONS INC / BABCOCK, E S & SONS, IN ✓	8/6/2019 ✓	N	N				BH90439-0267 ✓
WTR ANALYSES						9/6/2019 ✓	8/6/2019	\$0.00
9/5/2019 ✓					N			\$116.00 ✓
6	BABCOCK E S SONS INC / BABCOCK, E S & SONS, IN ✓	8/6/2019 ✓	N	N				BH90448-0267 ✓
LAB FEES						9/6/2019 ✓	8/6/2019	\$0.00
9/5/2019 ✓					N			\$244.00 ✓
7	BABCOCK E S SONS INC / BABCOCK, E S & SONS, IN ✓	8/6/2019 ✓	N	N				BH90451-0267 ✓
WTR ANALYSES						9/6/2019 ✓	8/6/2019	\$0.00
9/5/2019 ✓					N			\$96.00 ✓
8	BABCOCK E S SONS INC / BABCOCK, E S & SONS, IN ✓	8/6/2019 ✓	N	N				BH90465-0267 ✓
WTR ANALYSES						9/6/2019 ✓	8/6/2019	\$0.00
9/5/2019 ✓					N			\$32.00 ✓
9	BABCOCK E S SONS INC / BABCOCK, E S & SONS, IN ✓	8/7/2019 ✓	N	N				BH90532-0267 ✓
LAB FEES						9/7/2019 ✓	8/7/2019	\$0.00
9/5/2019 ✓					N			\$254.00 ✓
10	BABCOCK E S SONS INC / BABCOCK, E S & SONS, IN ✓	8/7/2019 ✓	N	N				BH90534-0267 ✓
LAB FEES						9/7/2019 ✓	8/7/2019	\$0.00
9/5/2019 ✓					N			\$190.00 ✓
11	BABCOCK E S SONS INC / BABCOCK, E S & SONS, IN ✓	8/7/2019 ✓	N	N				BH90542-0267 ✓
WTR ANALYSES						9/7/2019 ✓	8/7/2019	\$0.00
9/5/2019 ✓					N			\$84.00 ✓
12	BABCOCK E S SONS INC / BABCOCK, E S & SONS, IN ✓	8/7/2019 ✓	N	N				BH90543-0267 ✓
WTR ANALYSES						9/7/2019 ✓	8/7/2019	\$0.00
9/5/2019 ✓					N			\$420.00 ✓
13	BABCOCK E S SONS INC / BABCOCK, E S & SONS, IN ✓	8/7/2019 ✓	N	N				BH90544-0267 ✓
WTR ANALYSES						9/7/2019 ✓	8/7/2019	\$0.00
9/5/2019 ✓					N			\$168.00 ✓
14	BABCOCK E S SONS INC / BABCOCK, E S & SONS, IN ✓	8/7/2019 ✓	N	N				BH90546-0267 ✓
WTR ANALYSES						9/7/2019 ✓	8/7/2019	\$0.00
9/5/2019 ✓					N			\$84.00 ✓
15	BABCOCK E S SONS INC / BABCOCK, E S & SONS, IN ✓	8/8/2019 ✓	N	N				BH90675-0267 ✓
LAB FEES						9/8/2019 ✓	8/8/2019	\$0.00
9/5/2019 ✓					N			\$170.00 ✓
16	BABCOCK E S SONS INC / BABCOCK, E S & SONS, IN ✓	8/8/2019 ✓	N	N				BH90681-0267 ✓
WTR ANALYSES						9/8/2019 ✓	8/8/2019	\$0.00
9/5/2019 ✓					N			\$420.00 ✓
17	CARQUEST AUTO PARTS / CARQUEST AUTO PARTS ✓	8/7/2019 ✓	N	N				7456-416439 ✓
SUPPLIES						9/7/2019 ✓	8/7/2019	\$0.00
9/5/2019 ✓					N			\$6.76 ✓

**AP Enter Bills Edit Report**  
**Rubidoux Community Services District (RCSACT)**  
**Batch: AAAAGY**

8/28/2019 2:06:53 PM

Page 2

Tr. #	Vendor	Inv Date	Paid Out	Immediate	Credit Card Vendor	Due Date	Discount Date	Invoice #
PO Number		Immediate GL Account	GL Account	Check #	CC Reference #	Payment Date	Discount	Total Invoice
GL Date				Credit Card				
18	DE ANZA FENCE / DE ANZA FENCE CO ✓							9341 ✓
WELL 1A		8/7/2019 ✓	N	N		9/7/2019 ✓	8/7/2019	\$0.00
9/5/2019 ✓				N				\$5,895.00 ✓
19	HOME DEPOT / HOME DEPOT CREDIT SERVICES ✓							008038/3023850 ✓
SUPPLIES		8/8/2019 ✓	N	N		9/8/2019 ✓	8/8/2019	\$0.00
9/5/2019 ✓				N				\$672.70 ✓
20	KUMA TIRE / KUMA TIRE & WHEEL ✓							122736 ✓
R&M EQUIP		8/7/2019 ✓	N	N		9/7/2019 ✓	8/7/2019	\$0.00
9/5/2019 ✓				N				\$253.17 ✓
21	MERIT OIL / MERIT OIL COMPANY ✓							531871 ✓
DIESEL FUEL		8/7/2019 ✓	N	N		8/22/2019 ✓	8/7/2019	\$0.00
9/5/2019 ✓				N				\$284.57 ✓
22	R&D MECHANICAL / R&D MECHANICAL SUPPLY, INC ✓							11002846 ✓
STOCK		8/5/2019 ✓	N	N		9/5/2019 ✓	8/5/2019	\$0.00
9/5/2019 ✓				N				\$772.13 ✓
23	RELIABLE / RELIABLE WORKPLACE SOLUTIONS ✓							AR83368 ✓
SUPPLIES		7/17/2019 ✓	N	N		8/17/2019 ✓	7/17/2019	\$0.00
9/5/2019 ✓				N				\$8.95 ✓
24	STONE / STONE, ERIC ✓							12902800-06 ✓
RFND 6127 AV JUAN DI		8/9/2019 ✓	N	N		9/9/2019 ✓	8/9/2019	\$0.00
9/5/2019 ✓				N				\$34.91 ✓
25	VERIZON WIRELESS / VERIZON WIRELESS ✓							9835135002 ✓
CELL PHN CHGS		8/1/2019 ✓	N	N		8/24/2019 ✓	8/1/2019	\$0.00
9/5/2019 ✓				N				\$627.94 ✓
26	AQUA METRIC SALES / AQUA METRIC SALES CO ✓							INV0074761 ✓
MTR CABLES		8/13/2019 ✓	N	N		9/13/2019 ✓	8/13/2019	\$0.00
9/5/2019 ✓				N				\$1,009.41 ✓
27	AT&T / AT&T ✓							000013432957 ✓
PHONE CHGS		8/6/2019 ✓	N	N		9/13/2019 ✓	8/6/2019	\$0.00
9/5/2019 ✓				N				\$506.97 ✓
28	AWWA / AMERICAN WATER WORKS ASSOCIATION ✓							0001931712 ✓
DUES - SIMS		8/9/2019 ✓	N	N		9/9/2019 ✓	8/9/2019	\$0.00
9/5/2019 ✓				N				\$192.00 ✓
29	BPS B'S POOL SUPPLIES / B.P.S. B's POOL SUPPLIES ✓							99736 ✓
SODIUM HYPO		8/7/2019 ✓	N	N		9/7/2019 ✓	8/7/2019	\$0.00
9/5/2019 ✓				N				\$1,290.32 ✓
30	BABCOCK E S SONS INC / BABCOCK, E S & SONS, IN ✓							BG91346-0267 ✓
WTR ANALYSES		7/16/2019 ✓	N	N		8/16/2019 ✓	7/16/2019	\$0.00
9/5/2019 ✓				N				\$80.00 ✓
31	BABCOCK E S SONS INC / BABCOCK, E S & SONS, IN ✓							BG91841-0267 ✓
WTR ANALYSES		7/23/2019 ✓	N	N		8/23/2019 ✓	7/23/2019	\$0.00
9/5/2019 ✓				N				\$105.00 ✓
32	BABCOCK E S SONS INC / BABCOCK, E S & SONS, IN ✓							BH90848-0267 ✓
LAB FEES		8/12/2019 ✓	N	N		9/12/2019 ✓	8/12/2019	\$0.00
9/5/2019 ✓				N				\$190.00 ✓
33	BABCOCK E S SONS INC / BABCOCK, E S & SONS, IN ✓							BH90980-0267 ✓
WTR ANALYSES		8/13/2019 ✓	N	N		9/13/2019 ✓	8/13/2019	\$0.00
9/5/2019 ✓				N				\$96.00 ✓
34	BABCOCK E S SONS INC / BABCOCK, E S & SONS, IN ✓							BH91014-0267 ✓
WTR ANALYSES		8/13/2019 ✓	N	N		9/13/2019 ✓	8/13/2019	\$0.00
9/5/2019 ✓				N				\$32.00 ✓

**AP Enter Bills Edit Report**  
**Rubidoux Community Services District (RCSACT)**  
 Batch: AAAAGY

8/28/2019 2:06:53 PM

Page 3

Tr. #	Vendor	Inv Date	Paid Out	Immediate	Credit Card	Check #	Due Date	Discount Date	Invoice #
PO Number		Inv Date	Immediate GL Account					Payment Date	Discount
GL Date		Immediate GL Account			Credit Card	CC Reference #			Total Invoice
35	BABCOCK E S SONS INC / BABCOCK, E S & SONS, IN	8/13/2019	N	N	✓		9/13/2019	8/13/2019	BH91069-0267
LAB FEES									\$0.00
9/5/2019					N				\$254.00
36	BABCOCK E S SONS INC / BABCOCK, E S & SONS, IN	8/14/2019	N	N	✓		9/14/2019	8/14/2019	BH91110-0267
WTR ANALYSES									\$0.00
9/5/2019					N				\$42.00
37	BABCOCK E S SONS INC / BABCOCK, E S & SONS, IN	8/14/2019	N	N	✓		9/14/2019	8/14/2019	BH91111-0267
WTR ANALYSES									\$0.00
9/5/2019					N				\$420.00
38	BABCOCK E S SONS INC / BABCOCK, E S & SONS, IN	8/14/2019	N	N	✓		9/14/2019	8/14/2019	BH91141-0267
WTR ANALYSES									\$0.00
9/5/2019					N				\$420.00
39	BABCOCK E S SONS INC / BABCOCK, E S & SONS, IN	8/14/2019	N	N	✓		9/14/2019	8/14/2019	BH91145-0267
WTR ANALYSES									\$0.00
9/5/2019					N				\$174.00
40	BABCOCK E S SONS INC / BABCOCK, E S & SONS, IN	8/14/2019	N	N	✓		9/14/2019	8/14/2019	BH91173-0267
WTR ANALYSES									\$0.00
9/5/2019					N				\$290.00
41	BABCOCK E S SONS INC / BABCOCK, E S & SONS, IN	8/14/2019	N	N	✓		9/14/2019	8/14/2019	BH91106-0267
WTR ANALYSES									\$0.00
9/5/2019					N				\$210.00
42	BABCOCK E S SONS INC / BABCOCK, E S & SONS, IN	8/14/2019	N	N	✓		9/14/2019	8/14/2019	BH91107-0267
WTR ANALYSES									\$0.00
9/5/2019					N				\$84.00
43	BABCOCK E S SONS INC / BABCOCK, E S & SONS, IN	8/14/2019	N	N	✓		9/14/2019	8/14/2019	BH91108-0267
WTR ANALYSES									\$0.00
9/5/2019					N				\$168.00
44	BABCOCK E S SONS INC / BABCOCK, E S & SONS, IN	8/15/2019	N	N	✓		9/15/2019	8/15/2019	BH91228-0267
LAB FEES									\$0.00
9/5/2019					N				\$244.00
45	BABCOCK E S SONS INC / BABCOCK, E S & SONS, IN	8/15/2019	N	N	✓		9/15/2019	8/15/2019	BH91329-0267
WTR ANALYSES									\$0.00
9/5/2019					N				\$32.00
46	BABCOCK E S SONS INC / BABCOCK, E S & SONS, IN	8/15/2019	N	N	✓		9/15/2019	8/15/2019	BH91307-0267
WTR ANALYSES									\$0.00
9/5/2019					N				\$80.00
47	BABCOCK E S SONS INC / BABCOCK, E S & SONS, IN	8/15/2019	N	N	✓		9/15/2019	8/15/2019	BH91336-0267
WTR ANALYSES									\$0.00
9/5/2019					N				\$53.00
48	BABCOCK E S SONS INC / BABCOCK, E S & SONS, IN	8/15/2019	N	N	✓		9/15/2019	8/15/2019	BH91353-0267
WTR ANALYSES									\$0.00
9/5/2019					N				\$111.00
49	BOOT BARN / BOOT BARN	8/7/2019	N	N	✓		9/7/2019	8/7/2019	INV00005523
BOOTS - CANAL									\$0.00
9/5/2019					N				\$124.19
50	BOOT BARN / BOOT BARN	8/7/2019	N	N	✓		9/7/2019	8/7/2019	INV00005524
BOOTS - MATHESON									\$0.00
9/5/2019					N				\$152.24
51	CROWN ACE HARDWARE / CROWN ACE HARDWARE	8/9/2019	N	N	✓		9/9/2019	8/9/2019	078559
FASTENERS									\$0.00
9/5/2019					N				\$1.42

# AP Enter Bills Edit Report

Rubidoux Community Services District (RCSACT)  
Batch: AAAAGY

8/28/2019 2:06:53 PM

Page 4

Tr. #	Vendor	Inv Date	Paid Out	Immediate	Credit Card Vendor	Due Date	Discount Date	Invoice #
PO Number		Immediate GL Account	GL Account	Check #	Check #	Payment Date	Discount	
GL Date				Credit Card	CC Reference #		Total Invoice	
52	CROWN ACE HARDWARE / CROWN ACE HARDWARE ✓	8/12/2019 ✓	N	N		9/12/2019 ✓	8/12/2019	078575 ✓
PAINT							\$0.00	
9/5/2019 ✓				N			\$44.96 ✓	
53	CROWN ACE HARDWARE / CROWN ACE HARDWARE ✓	8/13/2019 ✓	N	N		9/13/2019 ✓	8/13/2019	078591 ✓
TOOL							\$0.00	
9/5/2019 ✓				N			\$14.00 ✓	
54	CROWN ACE HARDWARE / CROWN ACE HARDWARE ✓	8/14/2019 ✓	N	N		9/14/2019 ✓	8/14/2019	078601 ✓
R&M OFC							\$0.00	
9/5/2019 ✓				N			\$10.76 ✓	
55	CROWN ACE HARDWARE / CROWN ACE HARDWARE ✓	8/15/2019 ✓	N	N		9/15/2019 ✓	8/15/2019	078612 ✓
SUPPLIES							\$0.00	
9/5/2019 ✓				N			\$12.79 ✓	
56	DELL MARKETING LP / DELL MARKETING L.P. C/O DE ✓	8/7/2019 ✓	N	N		9/7/2019 ✓	8/7/2019	10332680403 ✓
COMPUTERS/MONITORS							\$0.00	
9/5/2019 ✓				N			\$16,407.75 ✓	
57	HARRINGTON INDUSTRIAL / HARRINGTON INDUSTRI ✓	8/7/2019 ✓	N	N		9/7/2019 ✓	8/7/2019	012J8040 ✓
PVC PARTS							\$0.00	
9/5/2019 ✓				N			\$485.05 ✓	
58	INLAND DESERT SECURITY / INLAND DESERT SECUI ✓	8/15/2019 ✓	N	N		9/15/2019 ✓	8/15/2019	190700636101 ✓
ANSWR SVC							\$0.00	
9/5/2019 ✓				N			\$463.60 ✓	
59	KH METALS / KH METALS & SUPPLY ✓	8/9/2019 ✓	N	N		9/9/2019 ✓	8/9/2019	0485506 ✓
SUPPLIES							\$0.00	
9/5/2019 ✓				N			\$20.36 ✓	
60	LAWNMOWER CENTER / LAWMOWER CENTER ✓	8/12/2019 ✓	N	N		9/12/2019 ✓	8/12/2019	09106 ✓
R&M EQUIP							\$0.00	
9/5/2019 ✓				N			\$14.16 ✓	
61	LUCE COMMUNICATIONS / LUCE COMMUNICATIONS: ✓	7/31/2019 ✓	N	N		8/31/2019 ✓	7/31/2019	2715933 ✓
WA41 FN 6/6							\$0.00	
9/5/2019 ✓				N			\$190.07 ✓	
62	LUCE COMMUNICATIONS / LUCE COMMUNICATIONS: ✓	7/31/2019 ✓	N	N		8/31/2019 ✓	7/31/2019	2715934 ✓
CLSNG BILLS 6/6							\$0.00	
9/5/2019 ✓				N			\$5.43 ✓	
63	MERIT OIL / MERIT OIL COMPANY ✓	8/9/2019 ✓	N	N		8/24/2019 ✓	8/9/2019	531892 ✓
GASOLINE							\$0.00	
9/5/2019 ✓				N			\$1,762.22 ✓	
64	PRO SYSTEMS INC / PRO SYSTEMS INC ✓	8/1/2019 ✓	N	N		9/1/2019 ✓	8/1/2019	01302 ✓
FXD ASSET SFTWR							\$0.00	
9/5/2019 ✓				N			\$295.00 ✓	
65	PRUDENTIAL OVERALL / PRUDENTIAL OVERALL SUP ✓	7/31/2019 ✓	N	N		8/31/2019 ✓	7/31/2019	22815150 ✓
FLR MTS							\$0.00	
9/5/2019 ✓				N			\$105.05 ✓	
66	PRUDENTIAL OVERALL / PRUDENTIAL OVERALL SUP ✓	8/14/2019 ✓	N	N		9/14/2019 ✓	8/14/2019	22848632 ✓
FLR MTS							\$0.00	
9/5/2019 ✓				N			\$112.28 ✓	
67	SCE / SCE ✓	8/20/2019 ✓	N	N		9/9/2019 ✓	8/20/2019	19S2323283572 ✓
SWR PMP ENRGY							\$0.00	
9/5/2019 ✓				N			\$391.92 ✓	
68	SCE / SCE ✓	8/20/2019 ✓	N	N		9/9/2019 ✓	8/20/2019	19S2317748135 ✓
SWR PMP ENRGY							\$0.00	
9/5/2019 ✓				N			\$2,727.13 ✓	

# AP Enter Bills Edit Report

Rubidoux Community Services District (RCSACT)

Batch: AAAAGY

8/28/2019 2:06:53 PM

Page 5

Tr. #	Vendor	Inv Date	Paid Out	Immediate	Credit Card Vendor	Due Date	Discount Date	Invoice #
PO Number		Immediate	GL Account		Check #		Payment Date	Discount
GL Date					Credit Card	CC Reference #		Total Invoice
69	SCE / SCE ✓							19S2036525988 ✓
SWR PMP ENRGY		8/20/2019 ✓	N	N		9/9/2019 ✓	8/20/2019	\$0.00
9/5/2019 ✓					N			\$777.80 ✓
70	SCE / SCE ✓							19S2271820763 ✓
WTR PMP ENRGY		8/17/2019 ✓	N	N		9/5/2019 ✓	8/17/2019	\$0.00
9/5/2019 ✓					N			\$232.45 ✓
71	SCE / SCE ✓							19S2352968572 ✓
WTR PMP ENRGY		8/17/2019 ✓	N	N		9/5/2019 ✓	8/17/2019	\$0.00
9/5/2019 ✓					N			\$753.71 ✓
72	SPECTRUM / SPECTRUM BUSINESS ✓							0914404080619 ✓
INTERNET 8/6-9/5		8/6/2019 ✓	N	N		8/23/2019 ✓	8/6/2019	\$0.00
9/5/2019 ✓					N			\$254.99 ✓
73	STREAMLINE / STREAMLINE ✓							101425 ✓
AUG '19 WEBSITE		8/18/2019 ✓	N	N		9/18/2019 ✓	8/18/2019	\$0.00
9/5/2019 ✓					N			\$400.00 ✓
74	UPS / UNITED PARCEL SERVICE ✓							0000F908W2319 ✓
POSTAGE		8/3/2019 ✓	N	N		9/3/2019 ✓	8/3/2019	\$0.00
9/5/2019 ✓					N			\$40.20 ✓
75	AIRGAS / AIRGAS USA, LLC ✓							9091823407 ✓
C02 TNKS		8/9/2019 ✓	N	N		9/8/2019 ✓	8/9/2019	\$0.00
9/5/2019 ✓					N			\$179.43 ✓
76	BABCOCK E S SONS INC / BABCOCK, E S & SONS, IN ✓							BH91477-0267 ✓
WTR ANALYSES		8/19/2019 ✓	N	N		9/19/2019 ✓	8/19/2019	\$0.00
9/5/2019 ✓					N			\$80.00 ✓
77	BABCOCK E S SONS INC / BABCOCK, E S & SONS, IN ✓							BH91548-0267 ✓
WTR ANALYSES		8/20/2019 ✓	N	N		9/20/2019 ✓	8/20/2019	\$0.00
9/5/2019 ✓					N			\$105.00 ✓
78	BABCOCK E S SONS INC / BABCOCK, E S & SONS, IN ✓							BH91510-0267 ✓
WTR ANALYSES		8/19/2019 ✓	N	N		9/19/2019 ✓	8/19/2019	\$0.00
9/5/2019 ✓					N			\$32.00 ✓
79	BABCOCK E S SONS INC / BABCOCK, E S & SONS, IN ✓							BH91512-0267 ✓
WTR ANALYSES		8/19/2019 ✓	N	N		9/19/2019 ✓	8/19/2019	\$0.00
9/5/2019 ✓					N			\$32.00 ✓
80	BABCOCK E S SONS INC / BABCOCK, E S & SONS, IN ✓							BH91576-0267 ✓
LAB FEES		8/20/2019 ✓	N	N		9/20/2019 ✓	8/20/2019	\$0.00
9/5/2019 ✓					N			\$190.00 ✓
81	BABCOCK E S SONS INC / BABCOCK, E S & SONS, IN ✓							BH91578-0237 ✓
WTR ANALYSES		8/20/2019 ✓	N	N		9/20/2019 ✓	8/20/2019	\$0.00
9/5/2019 ✓					N			\$96.00 ✓
82	BRINKS / BRINKS ✓							4453027 ✓
AUG '19 AMOR SVC		8/1/2019 ✓	N	N		9/1/2019 ✓	8/1/2019	\$0.00
9/5/2019 ✓					N			\$861.62 ✓
83	CITY OF JURUPA VALLEY / CITY OF JURUPA VALLEY ✓							234 ✓
PERMIT		8/19/2019 ✓	N	N		9/19/2019 ✓	8/19/2019	\$0.00
9/5/2019 ✓					N			\$422.35 ✓
84	CITY OF JURUPA VALLEY / CITY OF JURUPA VALLEY ✓							235 ✓
PERMIT		8/19/2019 ✓	N	N		9/19/2019 ✓	8/19/2019	\$0.00
9/5/2019 ✓					N			\$422.98 ✓
85	CITY OF JURUPA VALLEY / CITY OF JURUPA VALLEY ✓							243 ✓
PERMIT		8/19/2019 ✓	N	N		9/19/2019 ✓	8/19/2019	\$0.00
9/5/2019 ✓					N			\$428.01 ✓



**AP Enter Bills Edit Report**  
**Rubidoux Community Services District (RCSACT)**  
**Batch: AAAAGY**

8/28/2019 2:06:53 PM

Page 6

Tr. #	Vendor	Inv Date	Paid Out	Immediate	Credit Card Vendor	Due Date	Discount Date	Invoice #
PO Number		Immediate GL Account	GL Account		Check #		Payment Date	Discount
GL Date					Credit Card	CC Reference #		Total Invoice
86	COLE EQUIPMENT / COLE EQUIPMENT INC. ✓							30006 ✓
R&M OFC		8/13/2019 ✓	N	N		9/13/2019 ✓	8/13/2019	\$0.00
9/5/2019 ✓					N			\$650.44 ✓
87	CROWN ACE HARDWARE / CROWN ACE HARDWARE ✓							078616 ✓
R&M WTR		8/15/2019 ✓	N	N		9/15/2019 ✓	8/15/2019	\$0.00
9/5/2019 ✓					N			\$16.28 ✓
88	CROWN ACE HARDWARE / CROWN ACE HARDWARE ✓							078638 ✓
FASTENERS		8/19/2019 ✓	N	N		9/19/2019 ✓	8/19/2019	\$0.00
9/5/2019 ✓					N			\$0.45 ✓
89	DH WATER / D&H WATER SYSTEMS ✓							12019-0949 ✓
PUMP PRTS		8/13/2019 ✓	N	N		9/13/2019 ✓	8/13/2019	\$0.00
9/5/2019 ✓					N			\$5,191.31 ✓
90	HARRINGTON INDUSTRIAL / HARRINGTON INDUSTRI ✓							012J8219 ✓
PARTS		8/15/2019 ✓	N	N		9/15/2019 ✓	8/15/2019	\$0.00
9/5/2019 ✓					N			\$68.93 ✓
91	HARRINGTON INDUSTRIAL / HARRINGTON INDUSTRI ✓							012J8255 ✓
PVC PARTS		8/16/2019 ✓	N	N		9/16/2019 ✓	8/16/2019	\$0.00
9/5/2019 ✓					N			\$19.20 ✓
92	J THAYER / J THAYER COMPANY, INC ✓							1382866-0 ✓
SUPPLIES		8/15/2019 ✓	N	N		9/15/2019 ✓	8/15/2019	\$0.00
9/5/2019 ✓					N			\$220.53 ✓
93	MCMMASTER-CARR / McMASTER-CARR SUPPLY CO ✓							12703669 ✓
SUPPLIES		8/9/2019 ✓	N	N		9/9/2019 ✓	8/9/2019	\$0.00
9/5/2019 ✓					N			\$255.46 ✓
94	MCMMASTER-CARR / McMASTER-CARR SUPPLY CO ✓							12949092 ✓
TOOL		8/13/2019 ✓	N	N		9/13/2019 ✓	8/13/2019	\$0.00
9/5/2019 ✓					N			\$132.88 ✓
95	MERIT OIL / MERIT OIL COMPANY ✓							533154 ✓
GASOLINE		8/15/2019 ✓	N	N		8/30/2019 ✓	8/15/2019	\$0.00
9/5/2019 ✓					N			\$1,137.83 ✓
96	QUINN CAT / QUINN CAT / MACHINERY ✓							PCA00137634 ✓
R&M EQUIP		8/15/2019 ✓	N	N		9/14/2019 ✓	8/15/2019	\$0.00
9/5/2019 ✓					N			\$186.40 ✓
97	ROYAL INDUSTRIAL / ROYAL INDUSTRIAL SOLUTIONS ✓							6441-602511 ✓
PARTS		8/16/2019 ✓	N	N		9/16/2019 ✓	8/16/2019	\$0.00
9/5/2019 ✓					N			\$71.76 ✓
98	SOCAL TRUCK / SOCAL TRUCKWORKS ✓							8440 ✓
R&M TRK		8/19/2019 ✓	N	N		9/19/2019 ✓	8/19/2019	\$0.00
9/5/2019 ✓					N			\$64.78 ✓
99	SOCAL TRUCK / SOCAL TRUCKWORKS ✓							8432 ✓
R&M TRK		8/16/2019 ✓	N	N		9/16/2019 ✓	8/16/2019	\$0.00
9/5/2019 ✓					N			\$64.78 ✓
100	UNITED RENTALS / UNITED RENTALS, INC ✓							172735255-001 ✓
TOOL		8/15/2019 ✓	N	N		9/15/2019 ✓	8/15/2019	\$0.00
9/5/2019 ✓					N			\$80.65 ✓
101	AMERICAN SAFETY PRODUCTS / AMERICAN SAFETY ✓							2104 ✓
UNIFORMS - GONZALES		8/20/2019 ✓	N	N		9/20/2019 ✓	8/20/2019	\$0.00
9/5/2019 ✓					N			\$311.18 ✓
102	BPS B'S POOL SUPPLIES / B.P.S. B's POOL SUPPLIES ✓							100030 ✓
SODIUM HYPO		8/22/2019 ✓	N	N		9/22/2019 ✓	8/22/2019	\$0.00
9/5/2019 ✓					N			\$1,290.32 ✓



**AP Enter Bills Edit Report**  
**Rubidoux Community Services District (RCSACT)**  
 Batch: AAAAGY

8/29/2019 11:46:53 AM

Page 7

Tr. #	Vendor	Inv Date	Paid Out	Immediate	Credit Card Vendor	Due Date	Discount Date	Invoice #
PO Number		Immediate GL Account	Immediate GL Account		Check #		Payment Date	Discount
GL Date					Credit Card	CC Reference #		Total Invoice
103	BABCOCK E S SONS INC / BABCOCK, E S & SONS, IN ✓	8/21/2019 ✓	N	N				BH91686-0267 ✓
WTR ANALYSES						9/21/2019 ✓	8/21/2019	\$0.00
9/5/2019 ✓					N			\$32.00 ✓
104	BABCOCK E S SONS INC / BABCOCK, E S & SONS, IN ✓	8/21/2019 ✓	N	N				BH91687-0267 ✓
LAB FEES						9/21/2019 ✓	8/21/2019	\$0.00
9/5/2019 ✓					N			\$254.00 ✓
105	BABCOCK E S SONS INC / BABCOCK, E S & SONS, IN ✓	8/21/2019 ✓	N	N				BH91688-0267 ✓
LAB FEES						9/21/2019 ✓	8/21/2019	\$0.00
9/5/2019 ✓					N			\$244.00 ✓
106	BABCOCK E S SONS INC / BABCOCK, E S & SONS, IN ✓	8/21/2019 ✓	N	N				BH91690-0267 ✓
WTR ANALYSES						9/21/2019 ✓	8/21/2019	\$0.00
9/5/2019 ✓					N			\$116.00 ✓
107	BABCOCK E S SONS INC / BABCOCK, E S & SONS, IN ✓	8/21/2019 ✓	N	N				BH91702-267 ✓
WTR ANALYSES						9/21/2019 ✓	8/21/2019	\$0.00
9/5/2019 ✓					N			\$1,704.00 ✓
108	BABCOCK E S SONS INC / BABCOCK, E S & SONS, IN ✓	8/23/2019 ✓	N	N				BH91975-0267 ✓
LAB FEES						9/23/2019 ✓	8/23/2019	\$0.00
9/5/2019 ✓					N			\$872.00 ✓
109	BABCOCK E S SONS INC / BABCOCK, E S & SONS, IN ✓	8/27/2019 ✓	N	N				BH92262-0267 ✓
WTR ANALYSES						9/27/2019 ✓	8/27/2019	\$0.00
9/5/2019 ✓					N			\$420.00 ✓
110	BABCOCK E S SONS INC / BABCOCK, E S & SONS, IN ✓	8/27/2019 ✓	N	N				BH92278-0267 ✓
WTR ANALYSES						9/27/2019 ✓	8/27/2019	\$0.00
9/5/2019 ✓					N			\$32.00 ✓
111	BABCOCK E S SONS INC / BABCOCK, E S & SONS, IN ✓	8/27/2019 ✓	N	N				BH92298-0267 ✓
WTR ANALYSES						9/27/2019 ✓	8/27/2019	\$0.00
9/5/2019 ✓					N			\$116.00 ✓
112	BABCOCK E S SONS INC / BABCOCK, E S & SONS, IN ✓	8/27/2019 ✓	N	N				BH92299-0267 ✓
WTR ANALYSES						9/27/2019 ✓	8/27/2019	\$0.00
9/5/2019 ✓					N			\$658.00 ✓
113	BABCOCK E S SONS INC / BABCOCK, E S & SONS, IN ✓	8/27/2019 ✓	N	N				BH92300-0267 ✓
WTR ANALYSES						9/27/2019 ✓	8/27/2019	\$0.00
9/5/2019 ✓					N			\$180.00 ✓
114	BABCOCK E S SONS INC / BABCOCK, E S & SONS, IN ✓	8/27/2019 ✓	N	N				BH92303-0267 ✓
WTR ANALYSES						9/27/2019 ✓	8/27/2019	\$0.00
9/5/2019 ✓					N			\$96.00 ✓
115	BOOT BARN / BOOT BARN ✓	8/22/2019 ✓	N	N				CRE00001090 ✓
CREDIT						9/22/2019 ✓	8/22/2019	\$0.00
9/5/2019 ✓					N			(\$175.00) ✓
116	CARBON ACTIVATED / CARBON ACTIVATED CORPOR ✓	8/20/2019 ✓	N	N				45735 ✓
WELL 4 GAC TANKS						9/20/2019 ✓	8/20/2019	\$0.00
9/5/2019 ✓					N			\$150,000.00 ✓
117	CARBON ACTIVATED / CARBON ACTIVATED CORPOR ✓	8/21/2019 ✓	N	N				45746 ✓
WELL 4 TNKS FRGHT						9/21/2019 ✓	8/21/2019	\$0.00
9/5/2019 ✓					N			\$5,075.00 ✓
118	COMMERCIAL DOOR / COMMERCIAL DOOR COMPAN ✓	8/22/2019 ✓	N	N				73873 ✓
R&M OFC						9/22/2019 ✓	8/22/2019	\$0.00
9/5/2019 ✓					N			\$1,900.00 ✓
119	GRAINGER / GRAINGER ✓	8/15/2019 ✓	N	N				9264759474 ✓
SUPPLIES						9/15/2019 ✓	8/15/2019	\$0.00
9/5/2019 ✓					N			\$172.95 ✓





# AP Enter Bills Edit Report

Rubidoux Community Services District (RCSACT)  
Batch: AAAAGY

8/28/2019 2:06:53 PM

Page 8

Tr. #	Vendor	Inv Date	Paid Out	Immediate	Credit Card Vendor	Due Date	Discount Date	Invoice #
PO Number		Immediate GL Account	GL Account	Check #	CC Reference #	Payment Date	Discount	Total Invoice
120	CHASE CARD SERVICES / CHASE CARD SERVICES ✓	8/17/2019 ✓	N	N		9/11/2019 ✓	8/17/2019	19S315277049795 ✓
9/5/2019 ✓	FLAGS							\$0.00
9/5/2019 ✓					N			\$88.85 ✓
121	HARRINGTON INDUSTRIAL / HARRINGTON INDUSTRI ✓	8/19/2019 ✓	N	N		9/19/2019 ✓	8/19/2019	012J8287 ✓
9/5/2019 ✓	PVC PARTS							\$0.00
9/5/2019 ✓					N			\$40.02 ✓
122	HARRINGTON INDUSTRIAL / HARRINGTON INDUSTRI ✓	8/19/2019 ✓	N	N		9/19/2019 ✓	8/19/2019	012J8288 ✓
9/5/2019 ✓	PARTS							\$0.00
9/5/2019 ✓					N			\$205.81 ✓
123	INDUSTRIAL METAL / INDUSTRIAL METAL SUPPLY CC ✓	8/14/2019 ✓	N	N		9/14/2019 ✓	8/14/2019	328101 ✓
9/5/2019 ✓	STEEL							\$0.00
9/5/2019 ✓					N			\$184.01 ✓
124	JADTEC SECURITY / JADTEC SECURITY SVCS, INC. ✓	9/1/2019 ✓	N	N		9/11/2019 ✓	9/1/2019	2090843 ✓
9/5/2019 ✓	MONITORING SVC							\$0.00
9/5/2019 ✓					N			\$53.85 ✓
125	KH METALS / KH METALS & SUPPLY ✓	8/26/2019 ✓	N	N		9/26/2019 ✓	8/26/2019	0487312 ✓
9/5/2019 ✓	TOOL							\$0.00
9/5/2019 ✓					N			\$41.15 ✓
126	MCMASTER-CARR / McMASTER-CARR SUPPLY CO ✓	8/19/2019 ✓	N	N		9/19/2019 ✓	8/19/2019	13441718 ✓
9/5/2019 ✓	FREEZE KIT							\$0.00
9/5/2019 ✓					N			\$124.51 ✓
127	MERIT OIL / MERIT OIL COMPANY ✓	8/21/2019 ✓	N	N		9/5/2019 ✓	8/21/2019	534013 ✓
9/5/2019 ✓	GASOLINE							\$0.00
9/5/2019 ✓					N			\$722.42 ✓
128	MORTON SALT / MORTON SALT, INC. ✓	8/26/2019 ✓	N	N		9/26/2019 ✓	8/26/2019	5401908982 ✓
9/5/2019 ✓	SALT							\$0.00
9/5/2019 ✓					N			\$3,655.24 ✓
129	R&D MECHANICAL / R&D MECHANICAL SUPPLY, INC ✓	8/20/2019 ✓	N	N		9/20/2019 ✓	8/20/2019	11002869 ✓
9/5/2019 ✓	PARTS							\$0.00
9/5/2019 ✓					N			\$252.30 ✓
130	RELIABLE / RELIABLE WORKPLACE SOLUTIONS ✓	8/23/2019 ✓	N	N		9/23/2019 ✓	8/23/2019	AR84580 ✓
9/5/2019 ✓	COPIER USG							\$0.00
9/5/2019 ✓					N			\$173.40 ✓
131	RELIABLE / RELIABLE WORKPLACE SOLUTIONS ✓	8/23/2019 ✓	N	N		9/23/2019 ✓	8/23/2019	AR84581 ✓
9/5/2019 ✓	PRINTER USG							\$0.00
9/5/2019 ✓					N			\$35.97 ✓
132	SCE / SCE ✓	8/23/2019 ✓	N	N		9/11/2019 ✓	8/23/2019	19S2024179475.A ✓
9/5/2019 ✓	WTR PMP ENRGY							\$0.00
9/5/2019 ✓					N			\$33,385.11 ✓
133	SCE / SCE ✓	8/23/2019 ✓	N	N		9/11/2019 ✓	8/23/2019	19S2024179475.B ✓
9/5/2019 ✓	N03 PLNT ENRGY							\$0.00
9/5/2019 ✓					N			\$27,058.08 ✓
134	SCE / SCE ✓	8/23/2019 ✓	N	N		9/11/2019 ✓	8/23/2019	19S2024179475.C ✓
9/5/2019 ✓	FLD OFC UTLY							\$0.00
9/5/2019 ✓					N			\$314.47 ✓
135	TRAFFIC MANAGEMENT / TRAFFIC MANAGEMENT, IN ✓	8/19/2019 ✓	N	N		9/19/2019 ✓	8/19/2019	538881 ✓
9/5/2019 ✓	TRAFFIC CONES							\$0.00
9/5/2019 ✓					N			\$507.05 ✓
136	TKE ENGINEERING / TKE ENGINEERING, INC. ✓	8/21/2019 ✓	N	N		9/21/2019 ✓	8/21/2019	2019-483 ✓
9/5/2019 ✓	JURUPA HILLS LIFT ST							\$0.00
9/5/2019 ✓					N			\$12,335.91 ✓

*\$ 60,757.66*



# AP Enter Bills Edit Report

Rubidoux Community Services District (RCSACT)

Batch: AAAAGY

8/28/2019 2:06:53 PM

Page 9

Tr. #	Vendor	Inv Date	Paid Out	Immediate	Credit Card Vendor	Due Date	Discount Date	Invoice #
PO Number		Immediate GL Account	Immediate GL Account		Check #		Payment Date	Discount
GL Date					Credit Card	CC Reference #		Total Invoice
137	TKE ENGINEERING / TKE ENGINEERING, INC. ✓							2019-484 ✓
	AGUA MNSA BRINE LN	8/21/2019 ✓	N	N			9/21/2019 ✓ 8/21/2019	\$0.00 ✓
9/5/2019 ✓					N			\$5,697.56 ✓
138	EAGLE / EAGLE ROAD SVC & TIRE ✓							1-159980 ✓
	R&M JEEP	8/23/2019 ✓	N	N			9/23/2019 ✓ 8/23/2019	\$0.00 ✓
9/5/2019 ✓					N			\$68.19 ✓
139	BABCOCK E S SONS INC / BABCOCK, E S & SONS, IN ✓							BH92443-0267 ✓
	WTR ANALYSES	8/28/2019 ✓	N	N			9/28/2019 ✓ 8/28/2019	\$0.00 ✓
9/5/2019 ✓					N			\$32.00 ✓
140	BPS SUPPLY / BPS SUPPLY GROUP ✓							S2553952.001 ✓
	MN2 RPLCMT VLVS	8/28/2019 ✓	N	N			9/5/2019 ✓ 8/28/2019	\$0.00 ✓
9/5/2019 ✓					N			\$6,707.44 ✓
141	CLA-VAL / CLA-VAL ✓							778814 ✓
	R&M WTR MN 2	8/21/2019 ✓	N	N			9/21/2019 ✓ 8/21/2019	\$0.00 ✓
9/5/2019 ✓					N			\$2,578.85 ✓
142	CORELOGIC / CORELOGIC, INC. ✓							81976051 ✓
	ON-LINE SVCS	7/31/2019 ✓	N	N			8/30/2019 ✓ 7/31/2019	\$0.00 ✓
9/5/2019 ✓					N			\$178.75 ✓
143	GRAINGER / GRAINGER ✓							9268816205 ✓
	SUPPLIES	8/20/2019 ✓	N	N			9/19/2019 ✓ 8/20/2019	\$0.00 ✓
9/5/2019 ✓					N			\$59.04 ✓
144	GRAINGER / GRAINGER ✓							9268816213 ✓
	PARTS	8/20/2019 ✓	N	N			9/19/2019 ✓ 8/20/2019	\$0.00 ✓
9/5/2019 ✓					N			\$99.42 ✓
145	J THAYER / J THAYER COMPANY, INC ✓							1381083-0 ✓
	NAME PLATES	8/27/2019 ✓	N	N			9/27/2019 ✓ 8/27/2019	\$0.00 ✓
9/5/2019 ✓					N			\$30.17 ✓
146	KRIEGER & STEWART / KRIEGER & STEWART, INC. ✓							43518 ✓
	WASTEWTR CONSLT	8/23/2019 ✓	N	N			9/23/2019 ✓ 8/23/2019	\$0.00 ✓
9/5/2019 ✓					N			\$175.00 ✓
147	KRIEGER & STEWART / KRIEGER & STEWART, INC. ✓							43519 ✓
	PRETREATMENT	8/23/2019 ✓	N	N			9/23/2019 ✓ 8/23/2019	\$0.00 ✓
9/5/2019 ✓					N			\$5,271.05 ✓
148	KRIEGER & STEWART / KRIEGER & STEWART, INC. ✓							43520 ✓
	DISSLVD SOLIDS STUDY	8/23/2019 ✓	N	N			9/23/2019 ✓ 8/23/2019	\$0.00 ✓
9/5/2019 ✓					N			\$1,272.25 ✓
149	KRIEGER & STEWART / KRIEGER & STEWART, INC. ✓							43521 ✓
	WTR CNSLT	8/23/2019 ✓	N	N			9/23/2019 ✓ 8/23/2019	\$0.00 ✓
9/5/2019 ✓					N			\$5,242.35 ✓
150	KRIEGER & STEWART / KRIEGER & STEWART, INC. ✓							43522 ✓
	WELL 4 GAC	8/23/2019 ✓	N	N			9/23/2019 ✓ 8/23/2019	\$0.00 ✓
9/5/2019 ✓					N			\$500.00 ✓
151	LEGEND PUMP / LEGEND PUMP & WELL ✓							55845 ✓
	R&M WELL 4	8/28/2019 ✓	N	N			9/28/2019 ✓ 8/28/2019	\$0.00 ✓
9/5/2019 ✓					N			\$5,580.00 ✓
152	LEGEND PUMP / LEGEND PUMP & WELL ✓							55846 ✓
	R&M WELL 4	8/28/2019 ✓	N	N			9/28/2019 ✓ 8/28/2019	\$0.00 ✓
9/5/2019 ✓					N			\$36,214.00 ✓
153	R&D MECHANICAL / R&D MECHANICAL SUPPLY, INC ✓							11002881 ✓
	PARTS/TOOL	8/21/2019 ✓	N	N			9/21/2019 ✓ 8/21/2019	\$0.00 ✓
9/5/2019 ✓					N			\$1,243.01 ✓

# AP Enter Bills Edit Report

Rubidoux Community Services District (RCSACT)  
Batch: AAAAGY

8/28/2019 2:06:53 PM

Page 10

Tr. #	Vendor	Inv Date	Paid Out	Immediate	Credit Card Vendor	Due Date	Discount Date	Invoice #
PO Number		Immediate GL Account	Immediate GL Account	Check #	CC Reference #	Payment Date	Discount	Total Invoice
154	RICHARDS, WATSON, GERSHON / RICHARDS, WATSON	8/12/2019	N	N		9/12/2019	8/12/2019	222975
	CITY RVSD LITGN							\$0.00
9/5/2019					N			\$2,588.50
155	TRI-CO DISPOSAL INC / TRI-CO DISPOSAL, INC	8/28/2019	N	N		9/28/2019	8/28/2019	0807-082719.A
	COMM TRSH 8/7-8/27							\$0.00
9/5/2019					N			\$45,531.28
156	TRI-CO DISPOSAL INC / TRI-CO DISPOSAL, INC	8/28/2019	N	N		9/28/2019	8/28/2019	0807-082719.B
	RES TRSH 8/7-8/27							\$0.00
9/5/2019					N			\$132,367.77
157	TRI-CO DISPOSAL INC / TRI-CO DISPOSAL, INC	8/28/2019	N	N		9/28/2019	8/28/2019	0807-082719.C
	RCSD SHR COMM							\$0.00
9/5/2019					N			(\$4,554.68)
158	TRI-CO DISPOSAL INC / TRI-CO DISPOSAL, INC	8/28/2019	N	N		9/28/2019	8/28/2019	0807-082719.D
	RCSD SHR RES							\$0.00
9/5/2019					N			(\$1,312.69)
159	TRI-CO DISPOSAL INC / TRI-CO DISPOSAL, INC	8/28/2019	N	N		9/28/2019	8/28/2019	0807-082719.E
	BILLING FEE							\$0.00
9/5/2019					N			(\$3,000.00)

\$167,031.68

Grand Totals

Total Direct Expense: \$549,979.38  
 Total Direct Expense Adj: (\$9,042.37)  
 Total Non-Electronic Transactions: \$540,937.01

Report Summary

Report Selection Criteria  
 Report Type: Condensed  
 Start: Start End: End  
 Transaction Number: Start End

① 9,042.37  
 (8,867.37) - Trash  
 < 175.00 - credit memo Tr. #115  
0.00

② 540,937.01

Per Aerssch, 552,847.37  
 11,910.36

8-29-19

8/23/19  
 AP Payroll

9/6/19  
 AP Payroll

Union 240.00  
 Standard Ins. 2,751.65  
 SORMA 2,209.70  
 Colonial 2,578.71  
 VSP 994.34  
 Union 255.00  
 Lincoln 2,319.00  
 PayPro 64.23  
 AT+T 492.73 (separate batch)  
11,910.36

6. ACKNOWLEDGEMENTS – MEMBERS OF THE PUBLIC MAY  
ADDRESS THE BOARD AT THIS TIME ON ANY NON-AGENDA  
MATTER

7. CORRESPONDENCE AND RELATED INFORMATION

## Two Small Agencies Want a Divorce From the Water Authority. It Could Get Messy.

Posted By *Ry Rivard* On September 2, 2019 @ 4:00 am

---



Photo by Sam Hodgson

Back in January, the head of an obscure government agency that exists almost entirely to draw the boundary lines of other public agencies had gotten wind of something. Two rural water agencies wanted to bolt from the San Diego County Water Authority so they could start buying cheaper water from Riverside County.<sup>[1]</sup>

Keene Simonds knew what was in store for his agency, the San Diego Local Agency Formation Commission, which oversees things like where a city's limits end and where water districts can sell water.

This water thing, Simonds wrote in an email to a consultant, "could be a doozy".<sup>[2]</sup>

How much of a doozy is only now becoming clear.

In late August, the Water Authority's board approved spending up to \$1 million to hire a law firm to defend itself against the two water agencies that want to leave, the Fallbrook Public Utility District and the Rainbow Municipal Water District.

While there's no court action yet, the Water Authority is gearing up for what in the water world amounts to a rare change in relationship status. After decades buying water from the Water Authority, Rainbow and Fallbrook want a divorce.

The Water Authority was formed 75 years ago to buy water from the Colorado River and resell that water to local water agencies, like the city of San Diego's water department. Two dozen local water agencies now buy Water Authority water. Fallbrook was a founding member. Rainbow joined a decade later.

Rainbow and Fallbrook officials now believe they can save their 50,000 residents millions of dollars a year by leaving the Water Authority. Instead, they want to buy water from the Riverside-based Eastern Municipal Water District.

The Water Authority isn't going to just let that happen. The Water Authority is notoriously aggressive in court <sup>[3]</sup>, though its track record lately hasn't been great. Last year, it tried to interfere with the delivery of water to five local Indian tribes <sup>[4]</sup> that had been fighting for the water for 50 years. At stake there was a modest, one-time hit to the Water Authority's bottom line of about \$2 million.

The Water Authority lost <sup>[5]</sup>. A former federal judge assigned to settle the matter wrote that "it is beyond comprehension" <sup>[6]</sup> that the Water Authority "with a \$900 million budget, competent management, and skilled attorneys" did not find a way to deliver the water to the tribes without a hitch.

By comparison, Rainbow and Fallbrook's exit could cost the Water Authority about \$13 million a year, perhaps for years to come, according to some estimates <sup>[7]</sup> the Water Authority put together.

That's because the Water Authority spent billions planning to feed water to 24 water agencies from South Bay to North County. If Rainbow and Fallbrook leave, the other 22 agencies and their hundreds of thousands of customers will have to pay more, perhaps several bucks a year

on average. The largest of those remaining agencies would be the San Diego city water department.

If the divorce is too easy, there's also worry that other agencies may start looking for the door.

All this is partly because the Water Authority has succeeded at one thing: making the region's water supplies more reliable. But it's failed at another: keeping those same supplies affordable for everyone.

For years, the Water Authority was a go-between agency <sup>[8]</sup>. It just bought and resold water from the Metropolitan Water District of Southern California, which gathers water from the Colorado and from the rivers of Northern California for 19 million people.

Then, amid a drought in the early-1990s, there wasn't enough Metropolitan water to go around, which meant the Water Authority was in trouble too. San Diego was on the brink of being forced to cut its water use in half, a move that would have devastated farms and businesses and risked the region's way of life.

With the phrase "never again" ringing in their ears, Water Authority officials went out and bought rights to water from farmers in the Imperial Valley <sup>[9]</sup> and built a plant in Carlsbad that makes ocean water drinkable <sup>[10]</sup>. San Diego now doesn't have to rely so much on Metropolitan and should be able to weather droughts in the near future without much worry, but San Diego's water rates are now among the highest in the country <sup>[11]</sup>.

In some ways, whether anybody wants it to or not, the Rainbow and Fallbrook exit attempt all comes back to the Water Authority's long-running rivalry with Metropolitan <sup>[12]</sup>, a fight that has consumed Southern California water policy for the last quarter century.

In an Aug. 21 report on water prices <sup>[10]</sup>, Rainbow and Fallbrook show just how high the Water Authority's rates are by comparing them to Metropolitan's. Though the Water Authority has sued Metropolitan repeatedly over high rates <sup>[13]</sup>, it still buys some Metropolitan water, which the Water Authority then blends with its other supplies.

Water Authority water is \$500 more per acre foot than Metropolitan's <sup>[14]</sup>, according to Rainbow and Fallbrook's analysis, which was prepared with the help of a former senior Water Authority official who is now a consultant. (An acre foot is more water than two typical Southern California households use in a year.)



The water Rainbow and Fallbrook hope to buy from Eastern, the Riverside agency, is only about \$11 per acre foot more than Metropolitan's. That's because most of Eastern's water is Metropolitan water <sup>[15]</sup>. Eastern hasn't done things like the Water Authority has to expand its portfolio of water supplies.

But North County water agencies have worried for years about rising Water Authority costs. Part of the reason for the decline in the region's once-dominant avocado industry <sup>[16]</sup> is those higher rates.

The Water Authority offers a special rate to farmers, but Eastern's standard rate is still lower than that.

"For us, it's really about the cost of water," Fallbrook general manager Jack Bebee said.

The Water Authority's in-house general counsel, Mark Hattam, recalled a meeting where Bebee said he'd be willing to trade reliability for affordability.

"I don't know if the people in his service area believe that," Hattam said.

Since the drought in the 1990s, Metropolitan has also made its own investments, including a new reservoir in Riverside County and a series of deals meant to ensure access to Colorado River water <sup>[17]</sup>. The Water Authority may be hard-pressed to argue Metropolitan is totally unreliable, though. Two years ago the Water Authority paid a consultant to argue Metropolitan was at risk of having too much water <sup>[18]</sup>.

In the meantime, the major issue in San Diego seems to be an alimony payment of sorts that the Water Authority wants from Rainbow and Fallbrook so that other agencies aren't left holding the bag.

The Water Authority has yet to propose a figure. It wants Rainbow and Fallbrook to suggest something.

Rainbow and Fallbrook argue that there isn't a clear way to come up with such a figure for public water agencies. Using one series of numbers, the two agencies argue the Water Authority might actually owe them money, for assets the two agencies helped pay for that others benefit from, though that seemed to be floated more as a thought experiment than an actual request for money. Rainbow and Fallbrook mostly just want to leave without a massive fight.

In the meantime this will all be sorted out by not one but two Local Agency Formation Commissions, which are created by state law and known as LAFCOs. There's another such commission in Riverside County that may help the San Diego LAFCO sort out this county line-crossing water deal.

Simonds stands by his initial assessment of what's about to happen.

"I still think it's a doozy, because nobody has ever asked the question that Rainbow and Fallbrook are asking now," he said.

The Water Authority's law firm on this front is Lewis Brisbois Bisgaard & Smith, the firm that'll get up to \$1 million.

Hattam said hiring the firm was a must because the Water Authority has to quickly get up to speed on something that Rainbow and Fallbrook have been working on for months.

"We were behind the eight ball and we have to have legal counsel," he said.

Though Fallbrook and Rainbow's intentions weren't public until this spring, the divorce seems to have been in the works since at least last fall, according to documents the Water Authority obtained through Public Records Act requests it sent to Fallbrook, Rainbow and the San Diego LAFCO. Voice of San Diego, in turn, requested the records from the Water Authority.

In theory, the two agencies' customers wouldn't notice much difference – except for cheaper water. The water would still come from the same rivers and through the same pipes after leaving the same water treatment plant.

But on paper, everything would be different.

In an email that the Water Authority obtained in its document request, Rainbow general manager Tom Kennedy said he's argued for years that the Water Authority's rates and financial forecasts don't deal well with agencies that plan to buy less water from the Water Authority, but his arguments went nowhere.

Perhaps that's because other Water Authority members, like the city of San Diego, have their own plans, not for a complete divorce, but for a little bit of distance. The city, which is far larger than Rainbow and Fallbrook combined, plans to get a third of its water in the future by recycling wastewater. Part of the justification for that project is to avoid the Water Authority's rising prices <sup>[19]</sup>, though the city doesn't expect its recycled water will be cheaper for another three decades.

If the city does end up buying less water, rates for other agencies – like Rainbow and Fallbrook – could increase. If they're still part of the Water Authority.

---

Article printed from Voice of San Diego: <https://www.voiceofsandiego.org>

URL to article: <https://www.voiceofsandiego.org/topics/government/two-small-agencies-want-a-divorce-from-the-water-authority-it-could-get-messy/>

URLs in this post:

[1] so they could start buying cheaper water from Riverside County:

<https://www.voiceofsandiego.org/topics/government/two-agencies-plan-to-leave-the-san-diego-county-water-authority/>

[2] could be a doozy: <https://www.documentcloud.org/documents/6278989-6a-SDLAFCO-KS-Email-ConsultantKenLee-1-30-19.html#document/p1/a3>

[3] aggressive in court: <https://www.voiceofsandiego.org/topics/government/it-can-be-hard-to-tell-where-the-water-authority-ends-and-a-powerful-law-firm-begins/>

[4] interfere with the delivery of water to five local Indian tribes:

<https://www.voiceofsandiego.org/topics/science-environment/san-diegos-water-authority-reignited-century-old-water-dispute-local-tribes/>

[5] The Water Authority lost: <https://www.voiceofsandiego.org/topics/government/arbitrator-admonishes-water-authority-after-it-sued-five-tribes/>

[6] "it is beyond comprehension": <https://www.documentcloud.org/documents/5662962-Reasoned-Decision-on-Motion-for-Summary-Judgment.html#document/p35/a472307>

[7] according to some estimates: <https://www.documentcloud.org/documents/6362469-Preliminary-De-Annexation-Financial-Impact-8-22.html>

[8] the Water Authority was a go-between agency:

<https://www.voiceofsandiego.org/topics/government/under-iron-lady-of-water-san-diego-secured-its-own-supply-at-a-price/>

[9] bought rights to water from farmers in the Imperial Valley:

<https://www.voiceofsandiego.org/topics/government/san-diego-water-rates-fund-slaughterhouse-lots-stuff-imperial-county/>

[10] a plant in Carlsbad that makes ocean water drinkable:

<https://www.voiceofsandiego.org/topics/science-environment/desalination-plant-finished-debate-isnt/>

[11] among the highest in the country:

<https://www.voiceofsandiego.org/topics/government/san-diegans-pay-some-of-the-highest-water-rates-in-the-state-and-country/>

[12] long-running rivalry with Metropolitan:

<https://www.voiceofsandiego.org/topics/government/beef-week-socals-raging-water-agencies/>

[13] sued Metropolitan repeatedly over high rates:

<https://www.voiceofsandiego.org/topics/science-environment/court-ruling-throws-a-wrench-in->

## two-big-upcoming-water-decisions/

[14] Water Authority water is \$500 more per acre foot than Metropolitan's:

<https://www.documentcloud.org/documents/6362471-RMWD-FPUD-Detachment-Summary-for-SDCWA.html>

[15] most of Eastern's water is Metropolitan water: <https://www.emwd.org/water-supply>

[16] decline in the region's once-dominant avocado industry:

<https://www.voiceofsandiego.org/topics/science-environment/san-diegos-losing-its-grip-on-the-avocado-market/>

[17] a series of deals meant to ensure access to Colorado River water:

<https://www.voiceofsandiego.org/topics/science-environment/a-little-known-company-is-quietly-making-massive-water-deals/>

[18] Metropolitan was at risk of having too much water:

<https://www.voiceofsandiego.org/topics/science-environment/southern-california-is-drowning-in-drought-proofing-projects/>

[19] avoid the Water Authority's rising prices:

<https://www.voiceofsandiego.org/topics/government/heres-how-much-the-pure-water-project-could-raise-your-water-bill/>

Copyright © Voice of San Diego. All rights reserved.

8. MANAGER'S REPORT

- a) Operations Report
- b) Emergency and Incident Report

9. CONSIDERATION TO PURCHASE TWO REPLACEMENT  
(UTILITY BED TRUCKS) AND ONE NEW FLEET VEHICLES (1/2-  
TON PICKUP TRUCK):

**DM 2019-47**

# Rubidoux Community Services District

## Board of Directors

Christopher Barajas  
Armando Muniz  
Bernard Murphy  
F. Forest Trowbridge  
Hank Trueba Jr.



## Secretary-Manager

David D. Lopez

---

Water Resource Management    Refuse Collection    Street Lights    Fire / Emergency Services    Weed Abatement

**DIRECTORS MEMORANDUM 2019-47**

September 5, 2019

**To:**            Rubidoux Community Services District  
                  Board of Directors

**Subject:**    Authorize the Purchase of Two Replacement Water Department Utility Vehicles and One New Fleet Vehicle

## **BACKGROUND:**

On Thursday, August 20, 2019, the District received sealed bids for the replacement of two water department utility vehicles and the addition of one new water department vehicle. The proposed replacement vehicles include two 3/4-ton utility bed trucks and one 1/2-ton pickup truck. Separate bid documents were created for each vehicle to provide the most flexibility in purchasing options. Bidding documents were delivered to four dealers in the local area and two sealed bids received. Sunrise Ford in Fontana was the lowest bidder for all three vehicles.

If approved, the new trucks will replace the following fleet vehicles. Vehicle one is a 2013 Ford F250 utility bed truck (last five of the VIN 42078) with approximately 49,000 miles; vehicle two is a 2015 Ford F250 utility bed truck (last five of the VIN 71823) with approximately 96,000 miles; and vehicle three is a 2006 Ford Escape Hybrid SUV (last five of the VIN 68094) with approximately 12,000 miles.

As mentioned above, the low bids were submitted by Sunrise Ford in Fontana for a total bid of \$27,730.20 (including taxes, extended warranty, and trade-in) for vehicle 1; \$23,730.20 for vehicle 2; and \$25,654.73 for vehicle 3. A total of \$77,115.13 for all three vehicles. Copies of the bids are attached.

The vehicles were included in this year's water operating budget. The total budget for the vehicle replacement is \$95,000.00. A copy of the water operating budget is included for your information.

**RECOMMENDATION:**

Staff has reviewed all of the received bids and recommends the following to the Rubidoux Community Services Board of Directors:

Vehicle 1:

- 1a. Recognize the Bid for a 2019 Ford F250 utility bed truck submitted by Sunrise Ford for a total amount of \$27,730.20 as the lowest responsive bid (with extended warranty and trade-in); and
- 1b. Surplus the 2013 Ford F250 utility bed truck (VIN 1FTBF2A67DEB42078) and accept Sunrise Ford's trade-in offer \$10,500.00 for the truck.

Vehicle 2:

- 2a. Recognize the Bid for a 2019 Ford F250 utility bed truck submitted by Sunrise Ford for a total amount of \$23,730.20 as the lowest responsive bid (with extended warranty and trade-in); and
- 2b. Surplus the 2015 Ford F250 utility bed truck (VIN 1FTBF2A68GEA71823) and accept Sunrise Ford's trade-in offer \$14,500.00 for the truck.

Vehicle 3:

- 3a. Recognize the Bid for a 2019 Ford F150 pickup truck submitted by Sunrise Ford for a total amount of \$25,654.73 as the lowest responsive bid (with extended warranty and trade-in); and
- 3b. Surplus the 2006 Ford Escape Hybrid SUV (VIN 1FMCU95HX6KB68094) and accept Sunrise Ford's trade-in offer \$1,200.00 for the SUV.

Respectfully,

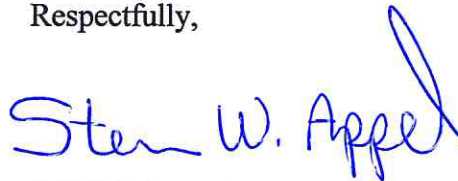

STEVEN W. APPEL, DPA, PE  
Assistant General Manager/  
District Engineer

Attachments:    Memo from Brian Jennings – August 20, 2019  
                          Sunrise Ford Bid – Vehicle 1 (Utility bed truck)  
                          Sunrise Ford Bid – Vehicle 2 (Utility bed truck)  
                          Sunrise Ford Bid – Vehicle 3 (pickup truck)  
                          2018/2019 Water Operating Fund Budget



**MEMORANDUM**

**DATE:** August 20, 2019

**TO:** Steve Appel, General Manager

**FROM:** Brian Jennings, Manager Budgeting and Accounting

**SUBJECT:** Utility Department Vehicle Replacement Truck Bid Results and Recommendation

On Thursday, August 20, 2019, staff opened sealed bids for Three (3) New Trucks.

Truck #1 is a Two-Wheel Drive, 8ft Utility Bed Truck Regular Cab (250), V8 with Automatic Transmission.

Truck #2 is a Two-Wheel Drive, 8ft Utility Bed Truck Regular Cab (250), V8 with Automatic Transmission.

Truck #3 is a Two-Wheel Drive, 6.5ft Regular Cab Pickup Truck (150), V6 with Automatic Transmission.

We requested bids from 4 different dealers for each vehicle.

The results are shown below. Additionally, we requested an additive bid for including a 5-year/100,000 mile extended warranty on the trucks which have been included in the summary.

Truck #1 Utility Bed									
Rank	Dealer	New Truck			Total Bid	Model Year	In Stock	Meets Specs	Delivery
		Bid	Warranty	Trade-In					
1	Sunrise Ford - Fontana	\$35,745.20	\$ 2,485.00	\$ (10,500.00)	\$ 27,730.20	2019	Yes	Yes	Meets
2	Raceway Ford - Riverside	\$35,506.99	\$ 1,535.00	\$ (9,000.00)	\$ 28,041.99	2019	Yes	Yes	Meets
3	Fritts Ford - Riverside	No Bid	No Bid	No Bid	No Bid	No Bid	No Bid	No Bid	No Bid
4	Velocity Truck Centers - Fontana	No Bid	No Bid	No Bid	No Bid	No Bid	No Bid	No Bid	No Bid

The low bidder for Truck #1 is Sunrise Ford and meets truck specifications.

Therefore, it is my recommendation that we issue a Purchase Order to Sunrise Ford for the amount of \$27,730.20 for One (1) Two-Wheel Drive, Utility Bed Truck Regular Cab (Ford 250), V8 with Automatic Transmission Recommend also that Sunrise Ford take the following vehicle in trade for (\$10,500.00):

- 2013 Ford F250 Utility Bed with approximately 49,000 miles, VIN# 1FTBF2A67DEB42078

Delivery is approximately 4 weeks from award date

Truck #2 Utility Bed									
Rank	Dealer	New Truck			Total Bid	Model Year	In Stock	Meets Specs	Delivery
		Bid	Warranty	Trade-In					
1	Sunrise Ford - Fontana	\$35,745.20	\$ 2,485.00	\$ (14,500.00)	\$ 23,730.20	2019	Yes	Yes	Meets
2	Raceway Ford - Riverside	\$35,506.99	\$ 1,535.00	\$ (11,800.00)	\$ 25,241.99	2019	Yes	Yes	Meets
3	Fritts Ford - Riverside	No Bid	No Bid	No Bid	No Bid	No Bid	No Bid	No Bid	No Bid
4	Velocity Truck Centers - Fontana	No Bid	No Bid	No Bid	No Bid	No Bid	No Bid	No Bid	No Bid

The low bidder for Truck #2 is Sunrise Ford and meets truck specifications.

Therefore, it is my recommendation that we issue a Purchase Order to Sunrise Ford for the amount of \$23,730.20 for One (1) Two-Wheel Drive, Utility Bed Truck Regular Cab (Ford 250), V8 with Automatic Transmission Recommend also that Sunrise Ford take the following vehicle in trade for (\$14,500.00):

- 2015 Ford F250 Utility Bed with approximately 96,000 miles, VIN# 1FTBF2A68GEA71823

**Truck #3 Pickup Truck  
New Truck**

Rank	Dealer	Bid	Warranty	Trade-In	Total Bid	Model Year	In Stock	Meets Specs	Delivery
1	Sunrise Ford - Fontana	\$24,449.73	\$ 2,405.00	\$ (1,200.00)	\$ 25,654.73	2019	Yes	Meets Specs	Meets
3	Raceway Ford - Riverside	\$26,898.75	\$ 880.00	\$ (2,100.00)	\$ 25,678.75	2019	Yes	Meets Specs	Meets
3	Fritts Ford - Riverside	No Bid	No Bid	No Bid	No Bid	No Bid	No Bid	No Bid	No Bid
4	Velocity Truck Centers - Fontana	No Bid	No Bid	No Bid	No Bid	No Bid	No Bid	No Bid	No Bid

The low bidder for Truck #3 is Sunrise Ford and meets truck specifications.

Therefore, it is my recommendation that we issue a Purchase Order to Sunrise Ford for the amount of \$25,654.73 for One (1) Two-Wheel Drive, 1/2 Ton Regular Cab Pickup Truck (Ford 150), V6 with Auto Transmission

Recommend also that Sunrise Ford take the following vehicle in trade for (\$10,500.00):

- 2006 Ford Escape Hybrid with approximately 12,000 miles, VIN# 1FMCU95HX6KB68094

Delivery is approximately 4 weeks from award date

**Total purchase price for the three (3) above vehicles is \$77,115.13, within the \$95,000**

**Board Authorized Water Department Budget**

**(see 2019/2020 Water Department Budget Lines # 45 & 46, Attached)**

SUNRISE FORD

TRUCK # 1

AUG 20 2019

Rubidoux Community Services District is a public agency located in the County of Riverside, California, and is eligible for all Standard Governmental Service Fleet Pricing and Warranties.

Additional equipment and/or upgraded modification should be listed as a separate item to allow an accurate and effective evaluation of submitted bids. All modifications to the minimum specifications, as stated above, shall be clearly identified. The quote should have 100,000 mile, 5 year, 6,000 engine hour extended warranties that should also be included in the submitted proposal and options for the vehicle.

The vehicle quoted price shall include all applicable state and local taxes, licenses, dealer transportation and preparation fees. Vehicles shall be "Highway Ready" with registration plates being filed "Exempt" by the dealer(s) with the Department of Motor Vehicles.

The above vehicles shall be fully fueled and lubricated.

RUBIDOUX COMMUNITY SERVICES DISTRICT

QUOTATION REQUEST

The Rubidoux Community Services District is requesting quotations to furnish and deliver equipment as described per attached District standard vehicle specification. Note: The total price quoted shall include all applicable taxes and delivery cost. "E" license are required.

<u>Term</u>	(1) Model Year 2019, 3/4 Ton 9,000 GVW or similar 8 FT Utility Bed Truck	PRICE \$ <u>33,053.24</u>
<u>Warranty</u>	100,000 Miles/5 Year; 6,000 Engine Hour (Extended Warranty)	\$ <u>2485.00</u> TAX \$ <u>2,691.96</u>
<u>Trade In Item</u>	2013 Ford F250 Utility Bed VIN # 1FTBF2A67DEB42078 Approximately 49K miles	\$( <u>10,500.00</u> ) TOTAL \$ <u>27,730.20</u>

The intended target vehicle is a 3/4 Ton, 4x2 Truck, V8, automatic. It is preferred that the winning bidder be able to deliver the vehicle within four (4) weeks or earlier of the award date. Otherwise bidder need provide best estimate of delivery date in bid quote.

The equipment quoted shall be furnished in compliance with the State of California Air Resource Board standards and as comparable to the attached specification sheets for delivery by **Friday, October 4, 2019 or earlier.**

**Proposals should arrive at the District office no later than 4:00 pm, Thursday, August 15, 2019.** It is anticipated that the District shall award the contract at the regularly scheduled meeting of the Board of Directors, September 5, 2019. The District will issue to the awarded dealer a Purchase Order for the vehicle the day following Board approval. Upon vehicle delivery and

TRUCK # 1

acceptance by the District, payment shall be made in full to the selected dealer within thirty (30) calendar days.

The District reserves the right to reject any and all bids received.

Written proposals should be submitted to: Attn: Brian Jennings  
Rubidoux Community Services District,  
3590 Rubidoux Blvd.  
Jurupa Valley, California 92509

Emailed proposals to: bjennings@rcsd.org

Faxed proposals may be transmitted to RCSD Attn: Brian Jennings at (951) 369-4061.

Said envelope shall also contain the following in the lower left-hand corner thereof:

Proposal of \_\_\_\_\_ (Name of Bidder) Tony Reed

For: One (1) Model Year 2019, 3/4 Ton, 8 Ft Utility Truck Bid

Signed:  Company: Sunrise Ford

Title: Fleet Manager Address: 16005 Valley Blvd

Date: 8/20/19 City: Fountain

Estimated Delivery Date: 10/14/19

TRUCK # 1

RUBIDOUX COMMUNITY SERVICES DISTRICT

3590 Rubidoux Blvd. P.O. Box 3098

Jurupa Valley, CA 92519

(951) 684-7580 - Fax (951) 369-4061

Utility Bed Truck

Vehicle Specifications

NOTE: Vendor must indicate either "Yes" or "No" in the columns labeled "Meets Spec".

	<u>Meets Spec.</u>	<u>Comments</u>
<b>Model:</b>		
8 FT Utility Bed Truck - 2 Door Regular Cab 2WD, 3/4-Ton GVW 9,000 or Similar	Yes	
<b>Color:</b>		
Exterior - White	Yes	
Interior - Any	Yes	Grey
<b>Cab:</b>		
Seats - Vinyl/Cloth	Yes	Vinyl
Flooring - Vinyl	Yes	
<b>Engine:</b>		
V8 Gasoline, 6.2 L or Similar, 430 Foot lbs Torque or similar EFI V8	Yes	
<b>Transmission:</b>		
5 or 6-Speed Automatic With Overdrive HD	Yes	6 speed
<b>Electrical:</b>		
Cold Cranking - 650 Amps or better Reserve Capacity - 115 Minutes or better	Yes	
<b>Cooling System:</b>		
Heavy Duty Radiator	Yes	
<b>Frame:</b>		
All-Welded Ladder Type	Yes	
<b>Suspension:</b>		
<b>Front:</b>		
Heavy Duty - Independent Coil Springs	Yes	
<b>Rear:</b>		
Heavy Duty - Semi-Elliptic, Two-Stage, Multi-Leaf	Yes	
<b>Axles:</b>		
Limited Slip, <u>Single Rear Wheels</u>	Yes	3.73

TRUCK # 1

Tires:

LT245/75R-17/D All Season Black wall (or better)	Yes	
Full Size Spare Tire W/ Steel Wheel		
17" Silver Painted Steel Wheel W/ Argent Center Cap		
Under-Body Mounted Locking Winch-Type Spare Tire Carrier		

Brakes:

Heavy Duty - Hydraulic Power 4 Wheel Disc Brakes	Yes	
---	-----	--

Fuel Tank:

Capacity - 30 Gallons or greater	Yes	
----------------------------------	-----	--

Battery:

HD 600 CCA Battery or better	Yes	
------------------------------	-----	--

Radio

AM/FM	Yes	
-------	-----	--

Air Conditioning

Factory Air Conditioner	Yes	
-------------------------	-----	--

Safety

4-Wheel Anti-Lock Brake System	Yes	
Driver & Front Passenger Airbags With Passenger Side Deactivation Switch		
Manual Lap/Shoulder Safety Belts, Outboard Seat Position		
Manual Lap Safety Belts, Center Seat Position		
Head Restraints At Outboard Seating Positions		
Daytime Running Lamps		

TRUCK # 1

	OR Equal	Meets Spec	Comments
Utility Body	See Attached (Last Pages) - <u>Scelzi</u> <u>Body/Harbor Trade Master or Equal</u>		
Locks	Internal Master Locks, Push Pull	- YES	SCELZI - Crown Series
Paint	Paint Factory White	- YES	
Bumper	Recessed Bumper (Weight Certificate)	- YES	
Lights	Legal Light Package With 7 wires Harness/ Wiring	- YES	
Trailer Hitch	Heavy Duty Tow Package	- YES	
Lid Covers	Aluminum or Stainless Open-Top Model Appearance Package	- YES	
Vise Brackets	Mounted On Left (Driver Side)	- YES	

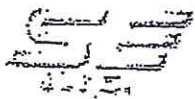

## 8 ft. Service Body Datasheet

### Standard Accessories and Features

- Chrome t-bar handle latches with polished stainless steel pockets and Galvaneal steel locking rods.
- Three point latching system on all compartment doors.
- Full-length, 5/16" stainless steel door shafts and hinge blocks with nylon inserts. On all compartment.
- All hinge blocks fastened with stainless steel mood bolts.
- All compartment doors equipped with barrel locks.
- Gas shocks on open top compartments.
- Seat-beam type tail and clearance lights.
- Gas shocks on all compartment doors.
- Scelzi exclusive floor seal.
- All bodies equipped with a six inch step bumper.
- Bodies fastened to frame at six mounting points.
- All seams are caulked with 3M ultra pro seam sealer.
- Complete under sealing of bed and wheel wells. Multiple coats of primer and urethane paint to maintain durability.
- Wiring built as harnesses and run thru loop clamps to prevent chafing and to secure mounting.
- Stainless steel tubing around wheel well openings.
- Self-leveling tailgate with stainless steel cap and guard rail. Diamond plate inner lining.
- *Vise Bracket - Mounted Left (Driver side)*

### Material

- Exterior structural body panels.
- Door post: 14 Gauge Galvaneal steel.
- End caps: 14 Gauge Galvaneal steel.
- Back wrapper: 14 Gauge Galvaneal steel.
- Closed tops and open top lids: 16 Gauge Galvaneal steel.
- Flooring: 12 Gauge diamond plate.
- Bulkhead: 14 Gauge Galvaneal steel.
- Interior structural body panels.
- Door skin: 18 Gauge Galvaneal steel.
- Inner door skin: 20 Gauge Galvaneal steel.

### Unacceptable Practices and Components

- Body mounting using only four points.
- Clip-in adjustable shelving.
- Single panel doors.
- Wiring running through interior of compartments.
- Shelving made from material other than 16 Gauge Galvaneal steel.
- Piano hinges on compartment doors.



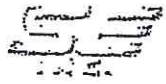

8 ft. Service Body Schematic

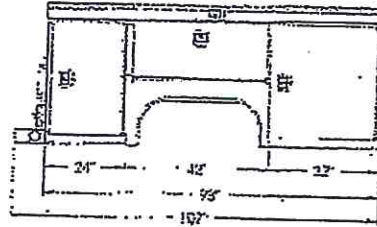
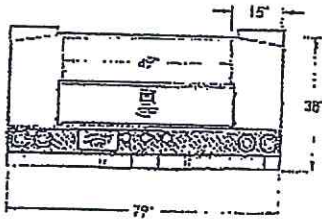
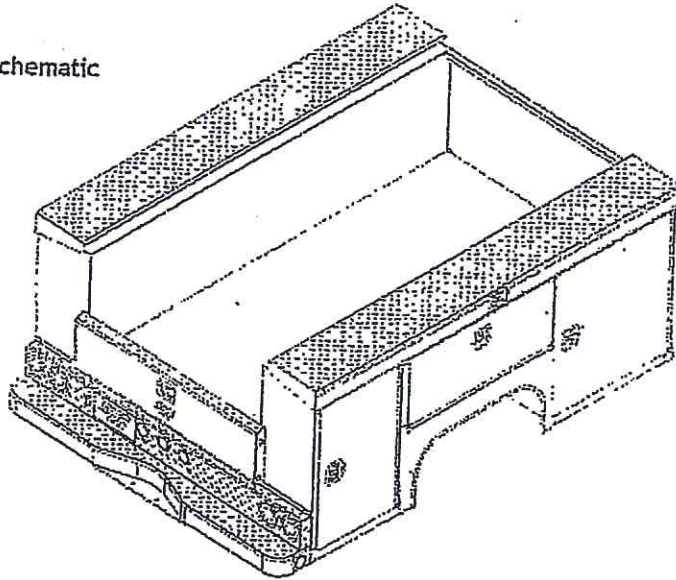

TRUCK #2

SUNRISE FORD

AUG 20 2019

Rubidoux Community Services District is a public agency located in the County of Riverside, California, and is eligible for all Standard Governmental Service Fleet Pricing and Warranties.

Additional equipment and/or upgraded modification should be listed as a separate item to allow an accurate and effective evaluation of submitted bids. All modifications to the minimum specifications, as stated above, shall be clearly identified. The quote should have 100,000 mile, 5 year, 6,000 engine hour extended warranties that should also be included in the submitted proposal and options for the vehicle.

The vehicle quoted price shall include all applicable state and local taxes, licenses, dealer transportation and preparation fees. Vehicles shall be "Highway Ready" with registration plates being filed "Exempt" by the dealer(s) with the Department of Motor Vehicles.

The above vehicles shall be fully fueled and lubricated.

## RUBIDOUX COMMUNITY SERVICES DISTRICT

### QUOTATION REQUEST

The Rubidoux Community Services District is requesting quotations to furnish and deliver equipment as described per attached District standard vehicle specification. Note: The total price quoted shall include all applicable taxes and delivery cost. "E" license are required.

<u>Term</u>	(1) Model Year 2019, 3/4 Ton 9,000 GVW or similar 8 FT Utility Bed Truck	PRICE \$ <u>33,053.24</u>
<u>Warranty</u>	100,000 Miles/5 Year; 6,000 Engine Hour (Extended Warranty)	\$ <u>2,485.00</u> TAX \$ <u>2,691.96</u>
<u>Trade In Item</u>	2015 Ford F250 Utility Bed VIN # 1FTBF2A68GEA71823 Approximately 96K miles	\$( <u>14,500.00</u> ) TOTAL \$ <u>23,730.20</u>

The intended target vehicle is a 3/4 Ton, 4x2 Truck, V8, automatic. It is preferred that the winning bidder be able to deliver the vehicle within four (4) weeks or earlier of the award date. Otherwise bidder need provide best estimate of delivery date in bid quote.

The equipment quoted shall be furnished in compliance with the State of California Air Resource Board standards and as comparable to the attached specification sheets for delivery by Friday, October 4, 2019 or earlier.

Proposals should arrive at the District office no later than 4:00 pm, Thursday, August 15, 2019. It is anticipated that the District shall award the contract at the regularly scheduled meeting of the Board of Directors, September 5, 2019. The District will issue to the awarded dealer a Purchase Order for the vehicle the day following Board approval. Upon vehicle delivery and

TRUCK # 2

acceptance by the District, payment shall be made in full to the selected dealer within thirty (30) calendar days.

The District reserves the right to reject any and all bids received.

Written proposals should be submitted to: Attn: Brian Jennings  
Rubidoux Community Services District,  
3590 Rubidoux Blvd.  
Jurupa Valley, California 92509

Emailed proposals to: bjennings@rcsd.org

Faxed proposals may be transmitted to RCSD Attn: Brian Jennings at (951) 369-4061.

Said envelope shall also contain the following in the lower left-hand corner thereof:

Proposal of \_\_\_\_\_ (Name of Bidder) Tony Reed

For: One (1) Model Year 2019, 3/4 Ton, 8 Ft Utility Truck Bid

Signed:  Company: Sunrise Ford

Title: Fleet Manager Address: 16005 Valley Blvd

Date: 8/20/19 City: Fontana

Estimated Delivery Date: 10/4/19

TRUCK #2

RUBIDOUX COMMUNITY SERVICES DISTRICT

3590 Rubidoux Blvd. P.O. Box 3098  
Jurupa Valley, CA 92519  
(951) 684-7580 - Fax (951) 369-4061

Utility Bed Truck

Vehicle Specifications

NOTE: Vendor must indicate either "Yes" or "No" in the columns labeled "Meets Spec".

	<u>Meets Spec.</u>	<u>Comments</u>
<b>Model:</b>		
8 FT Utility Bed Truck - 2 Door Regular Cab 2WD, 3/4-Ton GVW 9,000 or Similar	Yes	
<b>Color:</b>		
Exterior - White	Yes	
Interior - Any	Yes	Grey
<b>Cab:</b>		
Seats - Vinyl/Cloth	Yes	Vinyl
Flooring - Vinyl	Yes	
<b>Engine:</b>		
V8 Gasoline, 6.2 L or Similar, 430 Foot lbs Torque or similar EFI V8	Yes	
<b>Transmission:</b>		
5 or 6-Speed Automatic With Overdrive HD	Yes	6 speed
<b>Electrical:</b>		
Cold Cranking - 650 Amps or better Reserve Capacity - 115 Minutes or better	Yes	
<b>Cooling System:</b>		
Heavy Duty Radiator	Yes	
<b>Frame:</b>		
All-Welded Ladder Type	Yes	
<b>Suspension:</b>		
<b>Front:</b>		
Heavy Duty - Independent Coil Springs	Yes	
<b>Rear:</b>		
Heavy Duty - Semi-Elliptic, Two-Stage, Multi-Leaf	Yes	
<b>Axles:</b>		
Limited Slip, <u>Single Rear Wheels</u>	Yes	3.73

TRUCK #2

Tires:

LT245/75R-17/D All Season Black wall (or better)	yes	
Full Size Spare Tire W/ Steel Wheel		
17" Silver Painted Steel Wheel W/ Argent Center Cap		
Under-Body Mounted Locking Winch-Type Spare Tire Carrier		

Brakes:

Heavy Duty - Hydraulic Power 4 Wheel Disc Brakes	yes	
---	-----	--

Fuel Tank:

Capacity - 30 Gallons or greater	yes	
----------------------------------	-----	--

Battery:

HD 600 CCA Battery or better	yes	
------------------------------	-----	--

Radio

AM/FM	yes	
-------	-----	--

Air Conditioning

Factory Air Conditioner	yes	
-------------------------	-----	--

Safety

4-Wheel Anti-Lock Brake System	yes	
Driver & Front Passenger Airbags With Passenger Side Deactivation Switch		
Manual Lap/Shoulder Safety Belts, Outboard Seat Position		
Manual Lap Safety Belts, Center Seat Position		
Head Restraints At Outboard Seating Positions		
Daytime Running Lamps		

TRUCK #2

	OR Equal	Meets Spec	Comments
Utility Body	See Attached (Last Pages) - <u>Scelzi Body/Harbor Trade Master or Equal</u>		Scelzi - crown series
Locks	Internal Master Locks, Push Pull	- yes	
Paint	Paint Factory White	- yes	
Bumper	Recessed Bumper (Weight Certificate)	- yes	
Lights	Legal Light Package With 7 wires Harness/ Wiring	- yes	
Trailer Hitch	Heavy Duty Tow Package	- yes	
Lid Covers	Aluminum or Stainless Open-Top Model Appearance Package	- yes	
Vise Brackets	Mounted On Left (Driver Side)	- yes	

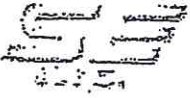

## 8 ft. Service Body Datasheet

### Standard Accessories and Features

- Chrome t-bar handle latches with polished stainless steel pockets and Galvaneal steel locking rods.
- Three point latching system on all compartment doors.
- Full-length, 5/16" stainless steel door shafts and hinge blocks with nylon inserts. On all compartment.
- All hinge blocks fastened with stainless steel mono bolts.
- All compartment doors equipped with barrel locks.
- Gas shocks on open top compartments.
- Seat-beam type tail and clearance lights.
- Gas shocks on all compartment doors.
- Seal exclusive door seal.
- All bodies equipped with a six inch step bumper.
- Bodies fastened to frame at six mounting points.
- All seams are caulked with 3M ultra pro seam sealer.
- Complete under sealing of bed and wheel wells. Multiple coats of primer and urethane paint to maintain durability.
- Wiring built as harnesses and run thru loop clamps to prevent chafing and to secure mounting.
- Stainless steel tubing around wheel well openings.
- Self-leveling tailgate with stainless steel cap and guard rail. Diamond plate inner lining.
- Vise Bracket - Mounted Left (Driver Side)

### Material

- Exterior structural body panels.
- Door post: 14 Gauge Galvaneal steel.
- End caps: 14 Gauge Galvaneal steel.
- Back wrapper: 14 Gauge Galvaneal steel.
- Closed tops and open top lids: 16 Gauge Galvaneal steel.
- Flooring: 12 Gauge diamond plate.
- Bulkhead: 14 Gauge Galvaneal steel.
- Interior structural body panels.
- Door skin: 18 Gauge Galvaneal steel.
- Inner door skin: 20 Gauge Galvaneal steel.

### Unacceptable Practices and Components

- Body mounting using only four points.
- Clip-in adjustable shelving.
- Single panel doors.
- Wiring running through interior of compartments.
- Shelving made from material other than 16 Gauge Galvaneal steel.
- Piano hinges on compartment doors.

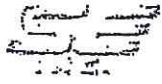

8 ft. Service Body Schematic

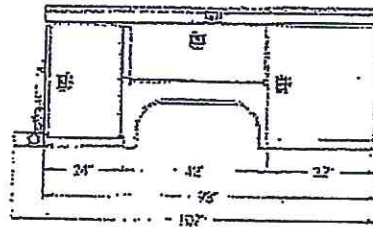
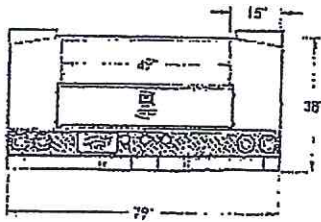
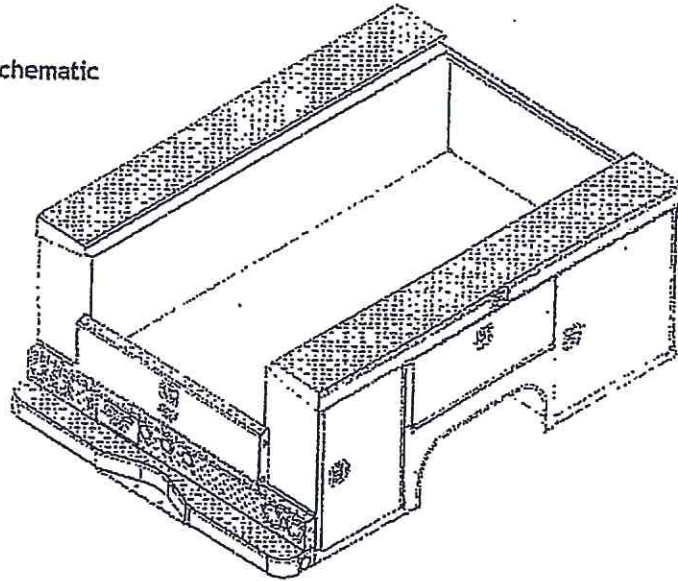



# 8-ft. TradeMaster

For 56" Cab-to-Axle Trucks with 8600 GVWR Minimum

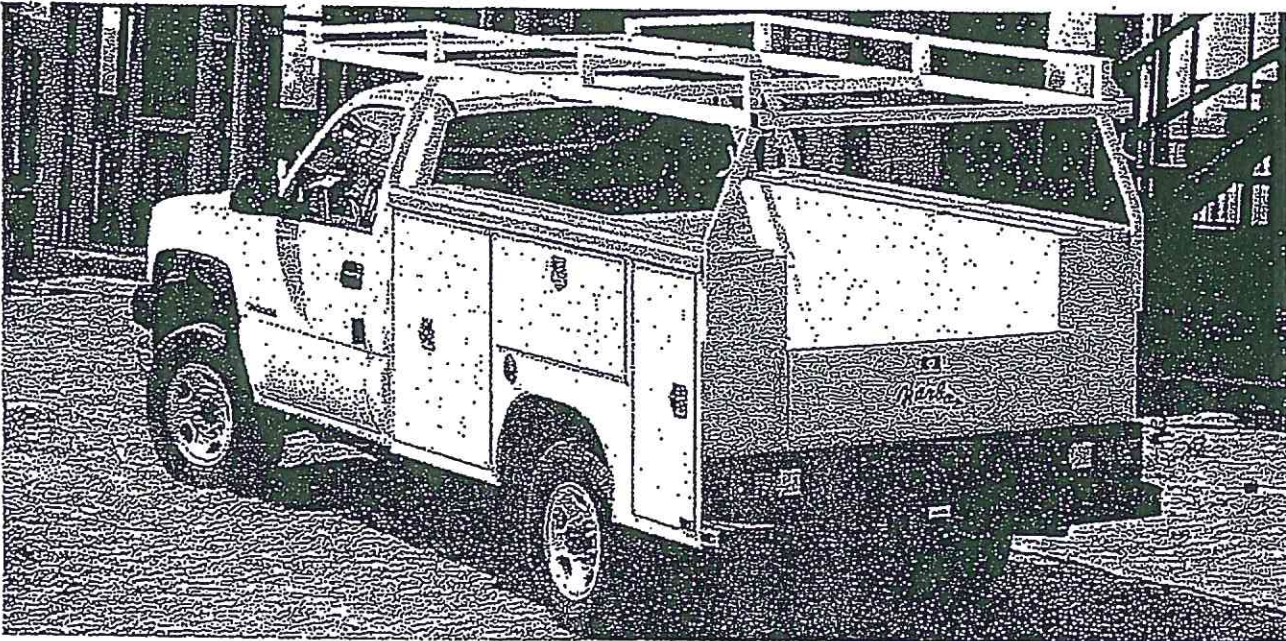

## 8-FT TRADEMASTER DIMENSIONS

STANDARD OPEN-TOP  
VERTICAL SERIES

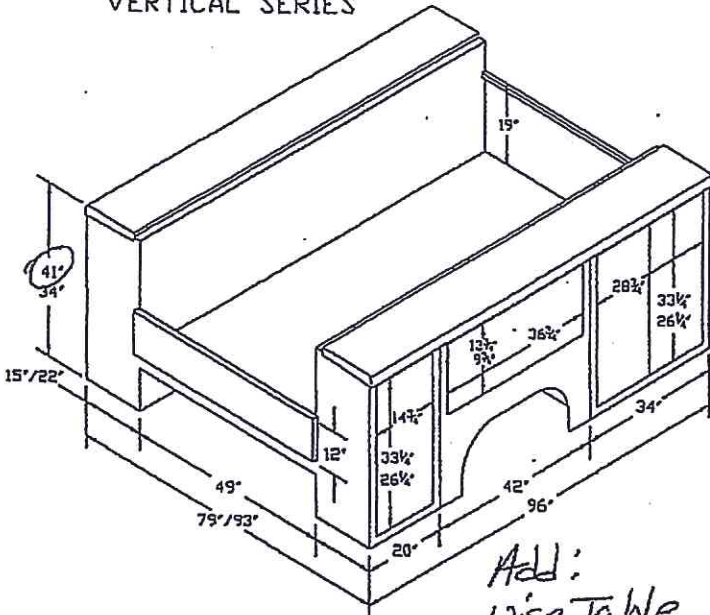

*Add:  
Use Table*

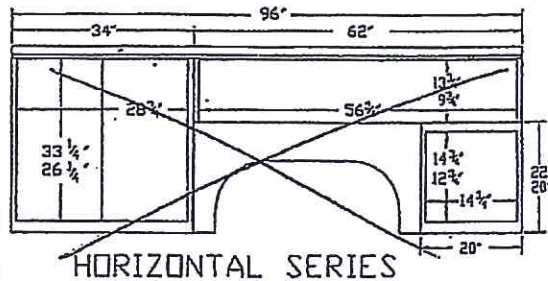

HORIZONTAL SERIES

CLOSED-TOP  
MODEL

OPEN-TOP  
MODEL

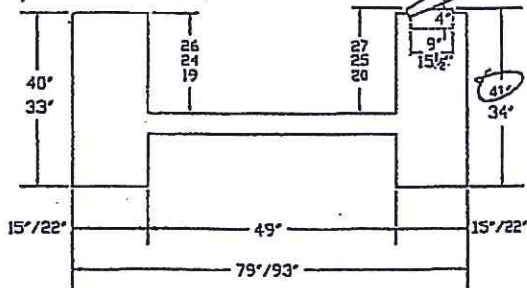

**NOTE:**

- DOOR COMPARTMENT DIMENSIONS ARE THE CLEAR DOOR OPENING.
- TOP VERTICAL DIMENSIONS ARE STANDARD HEIGHT BODIES  
BOTTOM DIMENSIONS ARE LOW PROFILE BODIES

SUNRISE FORD

AUG 20 2019

RUBIDOUX COMMUNITY SERVICES DISTRICT

TRUCK #3

TRUCK # 3

VEHICLE QUOTATION REQUEST

New 2019 Two-Wheel Drive, 1/2 Ton Regular Cab Pickup Truck 150 Series

The Rubidoux Community Services District (District) is requesting quotations to furnish and deliver equipment as described per attached District standard vehicle specification. NOTE: The total price quoted shall include all applicable taxes and delivery cost. "CA EXEMPT" License is required.

Items	Individual Unit Price	Tax & Delivery	Total Unit Price
BID ITEM 1: (1) New 2019 **Regular Cab** 6.5 Ft Bd Truck, V-6, or V-8, Auto Trans	22,570.20	1,879.53	\$ 24,449.73
BID ITEM 2: Extended Warranty (Beyond Factory); 100k/5 Year; 6,000 Engine Hour Warranty (\$100 Deductible)			\$ 2405.00
BID ITEM 3: Trade-In 2006 Ford Escape Hybrid Vin # 1FMCU95HX6KB68094 (Approx. 12k miles)			(\$ 1200.00)
Total Tax and Delivery			\$ 25,654.73

The equipment quoted shall be furnished in compliance with the State of California Air Resource Board standards for emissions and as comparable to the attached specification sheets for delivery on or before Friday, October 4, 2019. The District reserves the right to reject any and all proposals, to waive any irregularity and to award the contract based on the best bid to the District.

Proposals for the equipment herein indicated will be received by the District at its headquarters **no later than 4:00 PM, Thursday August 15, 2019.**

Proposals shall be made on District form and shall include a copy of the District Standard Vehicle Specification.

Delivery of the equipment will be at the following location:

Location: Rubidoux Community Services District  
Address: 3590 Rubidoux Blvd, Jurupa Valley, CA 92509

Bids may be Emailed, delivered, mailed or Faxed to the following address:  
Rubidoux Community Services District; Attn: Brian Jennings

Emailed: bjennings@rcsd.org      Delivered to: 3590 Rubidoux Blvd., Jurupa Valley, CA 92509

Mailed to: P.O. Box 3098      Faxed to: Brian Jennings (951) 369-4061  
Jurupa Valley, CA 92519

Signed [Signature]  
Title Plant Manager  
Date 8/20/19

Company Sunrise Ford  
Address 16005 Valley Blvd  
City Fontana, CA

# RUBIDOUX COMMUNITY SERVICES DISTRICT

(1) New 2019 Two-Wheel Drive, Regular Cab Pickup Truck 150 Series

## TRUCK # 3 - Regular Cab Pickup Truck

**NOTICE TO AUTO DEALERS/MANUFACTURERS:**

Bids will be received at Rubidoux Community Services District (District) for one (1) 2019 Model Year Two-wheel drive, Regular Cab, 6.5 Ft Bed, Truck meeting all State and Federal highway regulations in addition to the following:

IT IS THE INTENT OF THE DISTRICT TO TAKE A VEHICLE "OFF THE LOT", HOWEVER CONFIGURATIONS GREATER THAN SPECIFIED BELOW WILL BE CONSIDERED. THE FOLLOWING IS CONSIDERED MINIMUM REQUIREMENTS.

	Meets Specs.	Comments/Exceptions
2019 Model Year	Yes	
Two Door	Yes	
Two-Wheel Drive	Yes	
V-6 or V-8 Gasoline Engine	Yes	V6
Automatic Transmission	Yes	
Air Conditioning	Yes	
Power Steering	Yes	
Power Brakes (ABS)	Yes	
GVW Package 6650 or Similar	Yes	
Manual Windows/Door Locks	No	automatic
Vinyl/Cloth Seats	Yes	Vinyl
Tires: 16 inch (or Taller)	Yes	
Full Size Spare Tire	Yes	
Exterior Color: White	Yes	
Interior Color: Grey (other colors will be considered)	Yes	Grey
AM/FM Radio	Yes	
6.5 foot Bed	Yes	
Trailer Tow Package and Wiring	Yes	
Delivery Date Friday, October 4, 2019 or earlier	Yes	

NOTE: Vendor must indicate either "Yes" or "No" in the column labeled "Meets Specs".

The intended target vehicle is a 1500 or 150 Series 4X2 Regular Cab, V-6 or V-8, automatic. The winning bidder should be able to deliver the vehicle within four (4) weeks of the award date, September 5, 2019 – with a delivery date of Friday, October 4, 2019 or earlier.

Rubidoux Community Services District is a public agency located in the City of Jurupa Valley, California, and is eligible for all Standard Governmental Service Fleet Pricing and warranties.

Additional equipment and/or upgraded modification should be listed as a separate item to allow an accurate and effective evaluation of submitted bids. All modifications to the minimum specifications, as stated above, shall be clearly identified. All warranties and guarantees shall also be included in the submitted proposal. District reserves the right to waive minor irregularities that may be contained within the proposal(s).

The vehicle quoted price shall include all applicable state and local taxes, licenses, dealer transportation and preparation fees. Vehicles shall be "Highway Ready" with registration plates being filed "CA Exempt" by the dealer with the Department of Motor Vehicles.

Written proposals should be submitted to: Attn: Brian Jennings  
 Rubidoux Community Services District, 3590 Rubidoux Boulevard,  
 Jurupa Valley, California 92509.  
[bjennings@rcsd.org](mailto:bjennings@rcsd.org)

Faxed proposals may be transmitted to RCSD Attn: Brian Jennings at (951) 369-4061.

Proposals should arrive at the District office no later than 4:00 pm, Thursday, August 15, 2019. It is anticipated that the District shall award the contract at the regularly scheduled meeting of the Board of Directors, September 5, 2019. The District will issue to the awarded dealer a Purchase Order for the vehicle the day following Board approval. Upon vehicle delivery and acceptance by the District, payment shall be made in full to the selected dealer within thirty (30) calendar days. The District reserves the right to reject any and all bids received.

# Rubidoux Community Services District Water Fund Budget

June 20, 2019

	Projected Year End 2018/2019	Budget 2018/2019	Proposed Budget 2019/2020	Proposed Budget 2020/2021
<b>Administrative Expense</b>				
37 Salaries Expense	1,270,500	1,300,000	1,317,100	1,369,100
38 Payroll Tax Expense	102,100	96,500	93,100	97,600
39 Health & Retirement Expense	564,100	650,000	548,300	574,600
40 Workers Comp Insurance	52,400	43,500	49,500	51,000
41 General Admin Expense	600,000	600,000	600,000	600,000
<b>Total Administrative Expense</b>	<b>\$2,589,100</b>	<b>\$2,690,000</b>	<b>\$2,608,000</b>	<b>\$2,692,300</b>
<b>Other Expense</b>				
42 SERIES 1998-Misc. Expense	1,500	-	1,500	1,500
43 MN Plnt 17-18 Interest Exp	120,600	117,500	114,300	107,900
44 Transfer to Unrestricted Reserves	297,248	388,565	159,800	460,700
<b>Total Other Expense</b>	<b>\$419,348</b>	<b>\$506,065</b>	<b>\$275,600</b>	<b>\$ 570,100</b>
<b>Total Expense</b>	<b>\$4,626,345</b>	<b>\$4,815,965</b>	<b>\$4,547,200</b>	<b>\$5,065,300</b>
<b>Asset Acquisitions</b>				
★ 45 Fleet Replacement	86,000	128,000	65,000	65,000
46 Pickup Truck	New	-	30,000	-
47 Field Ofc Imprvmt	New	-	50,000	-
48 AMR Equipment (Radio Read)	-	50,000	-	-
49 Crane Truck (35% Swr / 65% Wtr)	55,575	58,500	-	-
50 Vactor Replacement (35% Swr / 65% Wtr)	48,219	48,100	-	-
51 Well 2 GAC Vessels	New	-	155,000	-
<b>Total Asset Acquisitions</b>	<b>\$189,794</b>	<b>\$284,600</b>	<b>\$300,000</b>	<b>\$65,000</b>
<b>Long-Term Debt</b>				
52 Debt Service - MN Plant 17-18 Principal	243,600	246,700	249,900	256,300
<b>Total Long-Term Debt</b>	<b>\$243,600</b>	<b>\$246,700</b>	<b>\$249,900</b>	<b>\$256,300</b>
<b>TOTAL WATER EXPENSES</b>	<b>\$5,059,739</b>	<b>\$5,347,265</b>	<b>\$5,097,100</b>	<b>\$5,386,600</b>

**10. CLOSED EXECUTIVE SESSION – PURSUANT TO  
GOVERNMENT CODE SECTION 54956.8: REAL PROPERTY  
NEGOTIATIONS**

**PROPERTY: 5293 MISSION BLVD., JURUPA VALLEY, CA  
AGENCY NEGOTIATOR: STEVEN APPEL  
UNDER NEGOTIATION: PURCHASE/NO PURCHASE, PRICE,  
AND TERMS**

**11. CLOSED EXECUTIVE SESSION – PURSUANT TO  
GOVERNMENT CODE SECTION 54956.9: LEGAL COUNSEL  
STATUS ON LITIGATION CASE NO. CIVDS 1310520, CITY OF  
RIVERSIDE VS. RUBIDOUX COMMUNITY SERVICES DISTRICT**

12. DIRECTORS COMMENTS – NON-ACTION

13. ADJOURNMENT